

## BACnet MS/TP Unit Conditioner

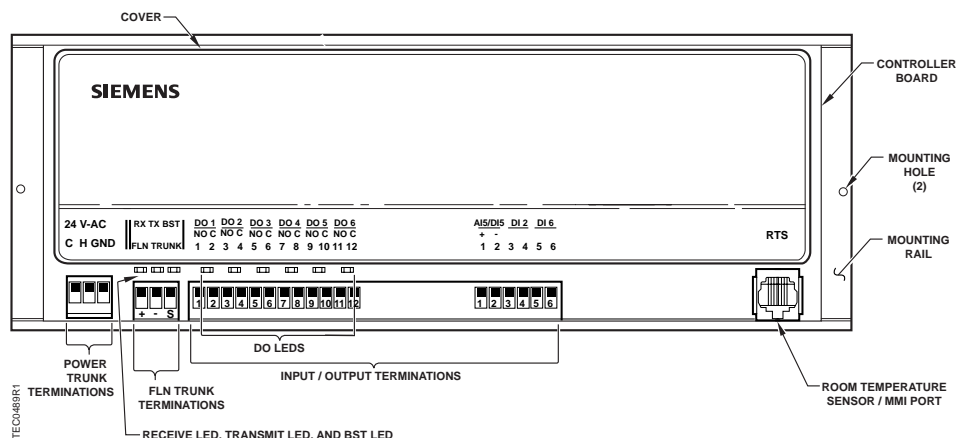

Figure 1. BACnet MS/TP Unit Conditioner.

### Control Applications

2540 and 2541

2550 through 2554

### Product Description

This document shows how to install a BACnet MS/TP Unit Conditioner Terminal Equipment Controller.

### Product Numbers

550-789A BACnet MS/TP Unit Conditioner  
FLN load: ¼ (See the Wiring Guidelines manual (125-3002) for more information on FLN loads.)

Shipping carton includes a controller assembly, mounting rail, and two self-tapping screws.



#### CAUTION:

Keep the unit in its static-proof bag until installation.

### Accessories

540-658P25 Low cost temporary temperature sensor that enables space control if the permanent room or duct sensor is not installed.

550-809 MOV with pre-terminated spade connectors

#### Parts for CE Compliance:

550-705 Clamp-on ferrite filter (10 pack).

588-100 series Approved 2-RJ11 RTS cable in 25', 50', or 100' (7.6 m, 15.2 m, 30.48 m).

529-488P10 MOV for Voltage/Current AI (10 pack)

### Caution Notation



#### CAUTION:

Equipment damage or loss of data may occur if you do not follow the procedures as specified.

### Expected Installation Times

10 minutes.

## Required Tools and Materials

- Electro-Static Discharge wrist strap
- Small flat-blade screwdriver
- Medium flat-blade screwdriver
- Cordless drill/driver set

## Prerequisites

- Wiring conforms to NEC and local codes and regulations. For further information refer to the Wiring Guidelines manual (125-3002).
- 24 Vac Class II power source available.
- Supply power to the controller is OFF.
- Any application specific hardware or devices installed.
- Room temperature sensor installed (optional).



If the controller is being installed on a box with 1 or more stages of electric heat, the 550-809 MOV with pre-terminated spade connectors must be installed across the manufacturer-supplied airflow switch. MOVs can be installed at the time the controller is factory mounted; coordinate with the box manufacturer prior to order placement. For field installation, see installation instructions 540-986.

## Instructions



All wiring must conform to NEC and local codes and regulations.

1. Secure the mounting rail (Figure 1) in the controller's desired location.
2. Place the ESD wrist strap on your wrist and attach it to a good earth ground.
3. Remove the controller from the static proof bag and snap it into place on the mounting rail.

4. Connect the FLN (Figure 2).

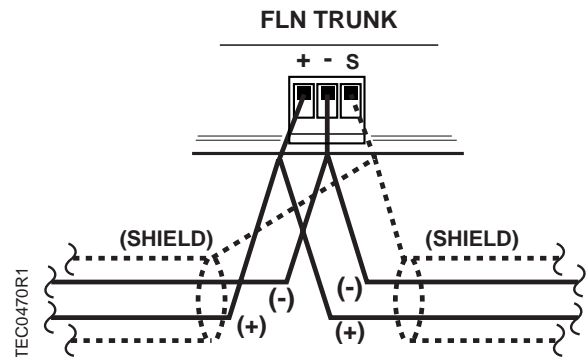

Figure 2. FLN Wiring.



### CAUTION:

Do not ground the shield.

5. Connect the point wiring (see Wiring Diagrams).
6. Plug the room temperature sensor cable into the RTS port (Figure 1).
7. Connect the power trunk (Figure 3). DO NOT apply power to the controller.

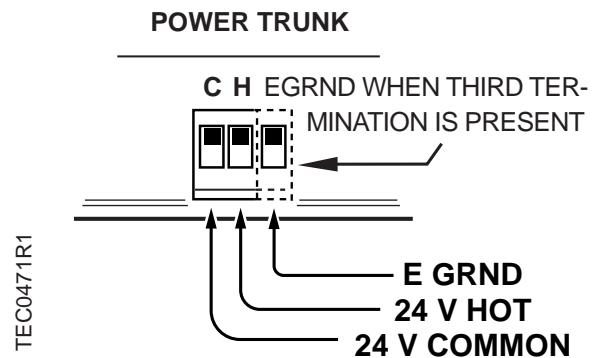

Figure 3. Power Trunk Wiring.



As a standard grounding procedure, ensure that 3"-5" ground wire is connected directly on the common terminal on the secondary side of the 24 Vac transformer.

The installation is complete.

## CE Compliance

If CE compliance is required, a ferrite filter must be placed approximately 1–2 cm from the end of the cable being shielded (RTS cable and any point wiring for AI5) (Figure 4).

- 1 Place the filter 1-2 cm from the end of the cable or wiring to be shielded.

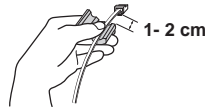

- 2 Wind the cable tightly twice around the filter.

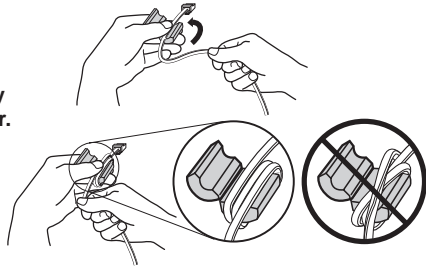

- 3 Close the filter and wrap with a zip tie.

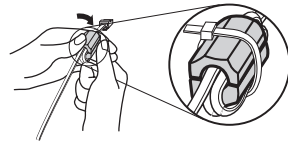
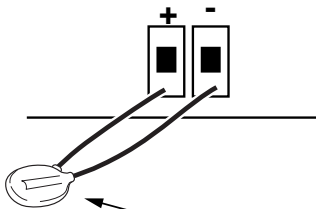

Figure 4. Ferrite filter(s) for CE Compliance.

An MOV (529-488P10) must be installed at AI5, if AI5 is used for input.

### ANALOG INPUT TERMINATIONS



ADD MOV TO EACH SPECIFIED AI

Figure 5. MOV for Voltage/Current AI.

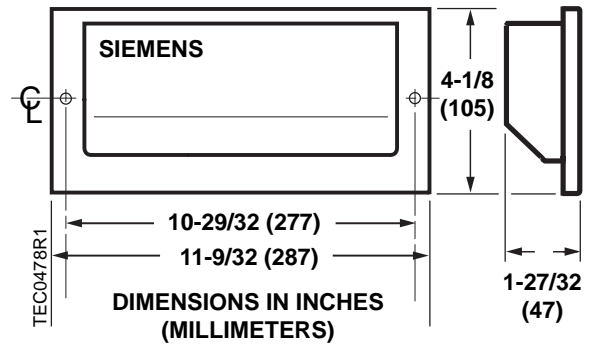
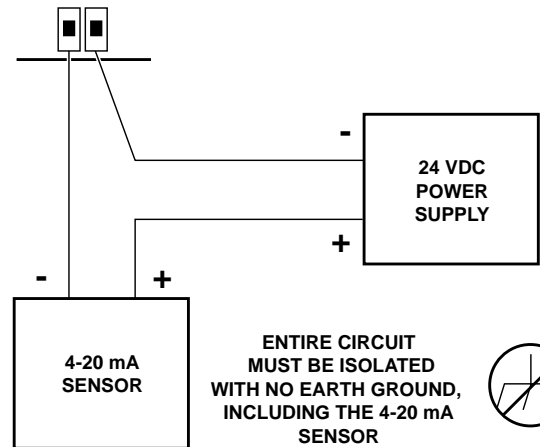

Figure 6. Dimensions.

## Wiring Diagrams

### ANALOG INPUT TERMINATIONS



### CAUTION:

Each 4-20mA sensor requires a SEPARATE, dedicated 24 VDC power supply. DO NOT use the same transformer to power both the sensor and controller.

TEC0462R2

Figure 7. Special Wiring Requirements for 4–20 mA Sensors.



### CAUTION:

The controller's DOs control 24 Vac loads only. The maximum rating is 12 VA for each DO. Use an interposing 24 Vac relay module (such as P/N 540-147) for any of the following:

- VA requirements higher than 12 VA
- Separate transformers to power the load
- Direct current (DC) power requirements

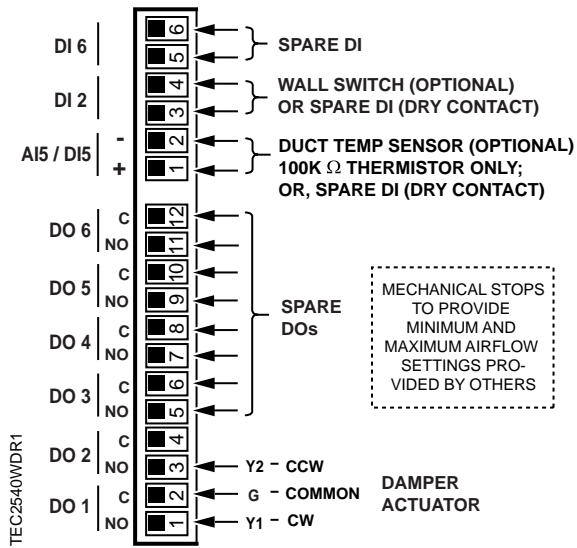

Figure 8. Application 2540 — Variable Air Volume Pressure Dependent Cooling or Heating.

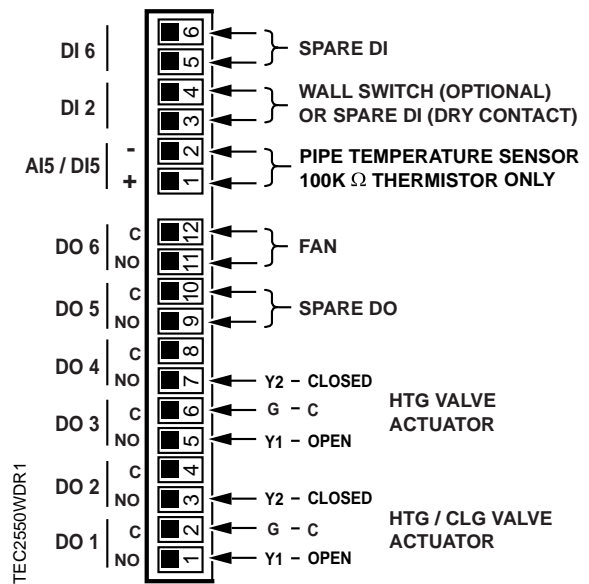

Figure 10. Application 2550 — Two-Pipe Fan Coil Unit Cooling or Heating.

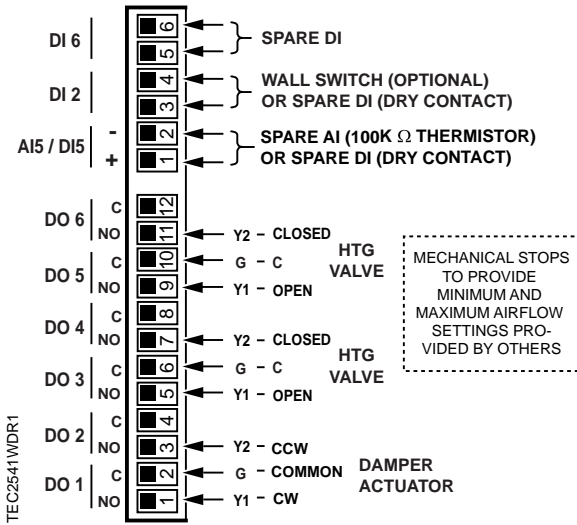

Figure 9. Application 2541 — Variable Air Volume Pressure Dependent with Hot Water Reheat.

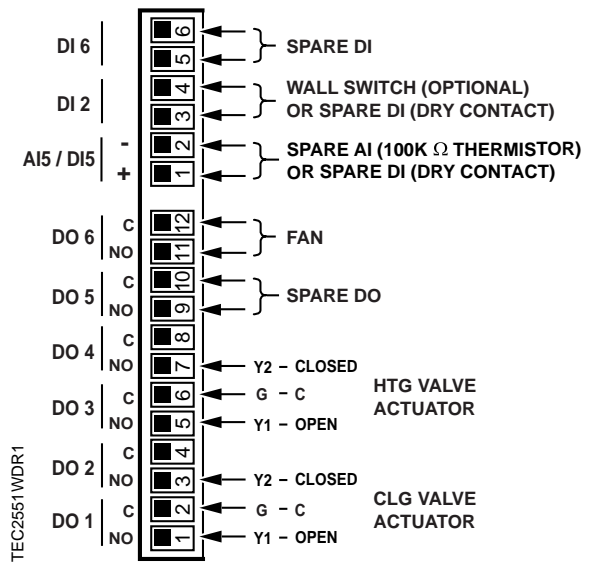

Figure 11. Application 2551 — Fan Coil Unit Cooling and Heating.

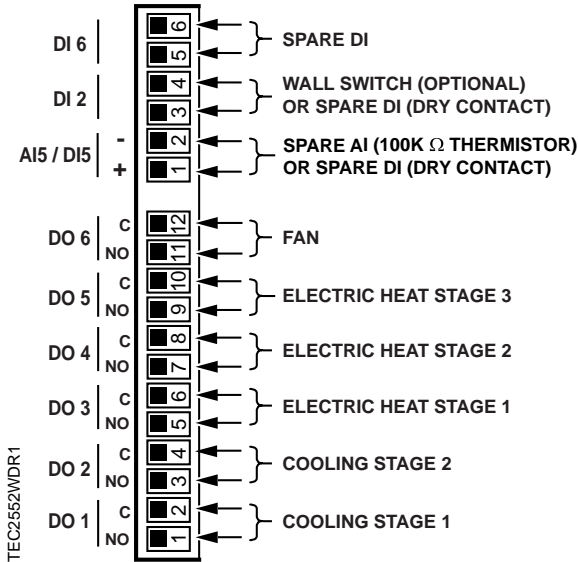

Figure 12. Application 2552 — Fan Coil Unit Cooling and Electric Heat.

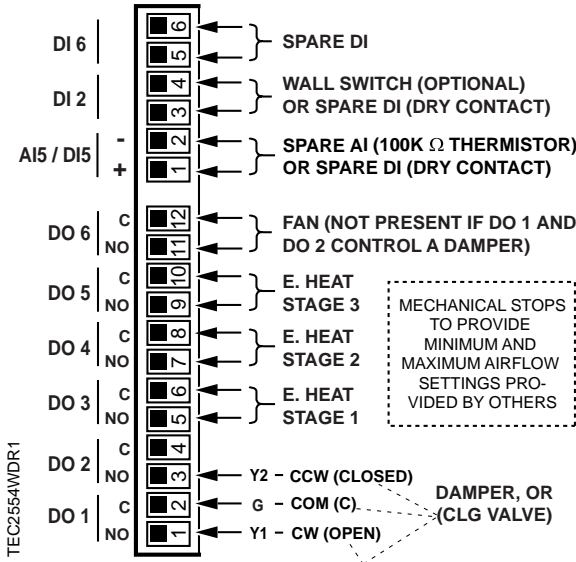

Figure 14. Application 2554 — Fan Coil Unit Cooling with Electric Heat.

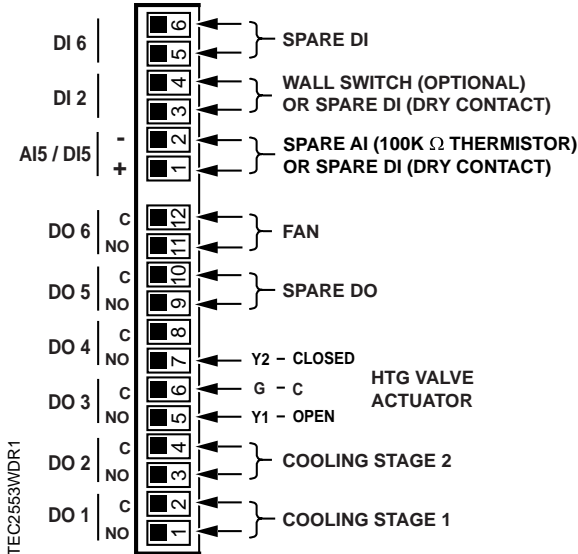

Figure 13. Application 2553 — Fan Coil Unit 2-Stage Cooling and Hot Water Heat.

Information in this document is based on specifications believed correct at the time of publication. The right is reserved to make changes as design improvements are introduced. Product or company names mentioned herein may be the trademarks of their respective owners.  
© 2007 Siemens Building Technologies, Inc.