

LONWORKS® Bus Wiring Guidelines

AK3797, AK3798, AK3799

USER'S GUIDE

INTRODUCTION

The Free Topology Transceiver (FTT) supports polarity insensitive, free topology wiring. This frees the system installer from wiring using a specific bus topology. T-tap, star, loop, and mixed wiring topologies are all supported by this architecture. Free topology wiring reduces the time and expense of system installation by allowing the wiring to be installed in the most expeditious manner. It also simplifies network expansion by eliminating restrictions on wire routing, splicing, and device placement.

A FTT network can be comprised of multiple segments (LONWORKS Bus sections containing from one to sixty devices, each device having a Neuron® ID to validate) separated by physical layer repeaters or routers.

FTT networks are very flexible and convenient to install and maintain, but it is imperative to carefully plan the network layout and create and maintain accurate documentation. This will aid in compliance verification and future expansion of the FTT network. This will also minimize unknown or inaccurate wire run lengths, node-to-node (device-to-device) distances, node counts, total wire length, inaccurate repeater/router locations, and misplaced or missing terminations.

APPLICATIONS

A free topology architecture allows the user to wire the control devices with virtually no topology restrictions.

Unlike bus wiring designs, the FTT system uses a free topology wiring scheme that supports T-tap, star, loop, mixed, and/or daisy-chain (see Fig. 1). This design has many advantages. First, the installer is free to select the method of wiring that best suits the installation, reducing the need for advanced planning and allowing last minute changes at the installation site. Second, if installers have been trained to use one style of wiring for all installations, free topology technology can be introduced without requiring retraining. Third, retrofit installations with existing wiring plans can be accommodated with minimal, if any, rewiring. This capability ensures that FTT technology can be adapted to both old and new projects, widening the potential market for FTT based products. Finally, free topology allows FTT systems easy future expansion by tapping into the existing wiring where it is most convenient to do so. This reduces the time and expense of system expansion, and from the customers perspective, keeps down the life cycle cost of the free topology network.

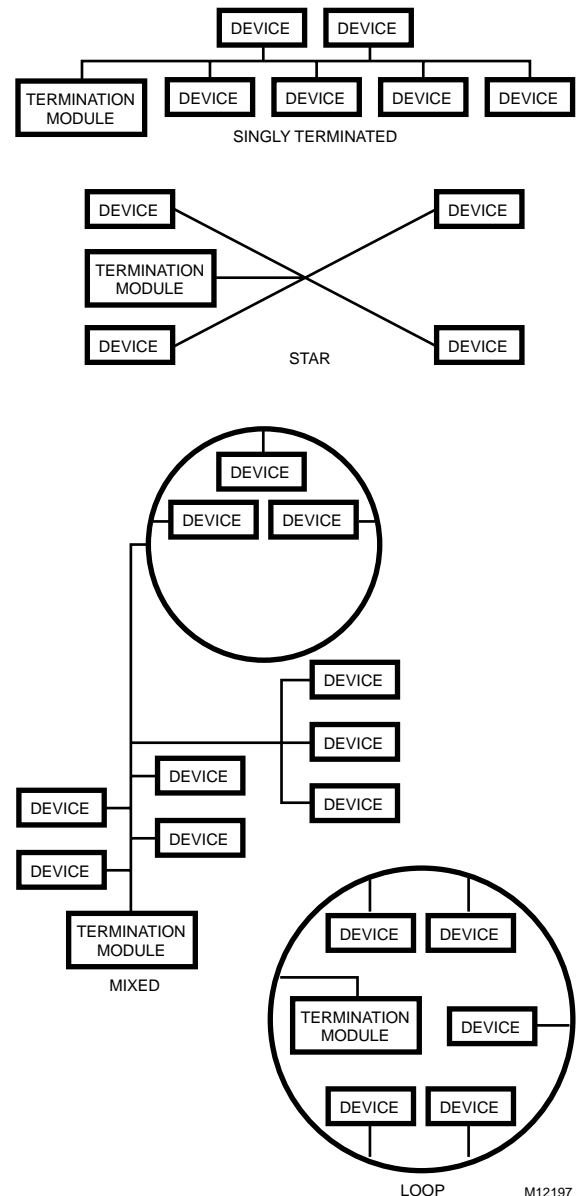

Fig. 1. Typical wiring topologies supported by the FTT System.

System expansion is simplified by the use of physical layer repeaters and routers. The Q7740A 2-Way or Q7740B 4-Way Devices perform a repeater function, and the Q7751A operates as a router. See Fig. 2. If a LONWORKS Bus segment grows beyond the maximum number of devices or total wire distance, then additional FTT segments can be added. This is done by connecting a Q7740A 2-Way or a Q7740B 4-Way physical layer repeater (see Fig. 3). The repeaters will transfer data between the two LONWORKS Bus segments, this allows the number of devices to be spread out as well as increasing the length of wire over which they communicate.

NOTE: Do not exceed the maximum of 120 devices for a Q7750A Zone Managers LONWORKS Bus network (up to 60 devices are allowed per LONWORKS Bus segment).

The repeater function permits an FTT network to grow as system needs expand, without retrofitting existing controllers or requiring the use of specialized bridges. The maximum number of repeaters per LONWORKS Bus segment is one (on either side of the router). A Q7751A LONWORKS Bus Router can also be used to effectively double the maximum LONWORKS Bus length. The advantage of using the router is that it will segregate traffic to an LONWORKS Bus segment, when using the repeater all traffic is repeated on each LONWORKS Bus segment. (see following NOTES).

NOTES:

- There can be no more than one repeater on either side of a Q7751A Router.
- An FTT network can have no more than one router per Zone Manager. Systems requiring high levels of network traffic may benefit from the use of a Q7751A Router which forwards packets only when necessary. Routers are not allowed within loops.

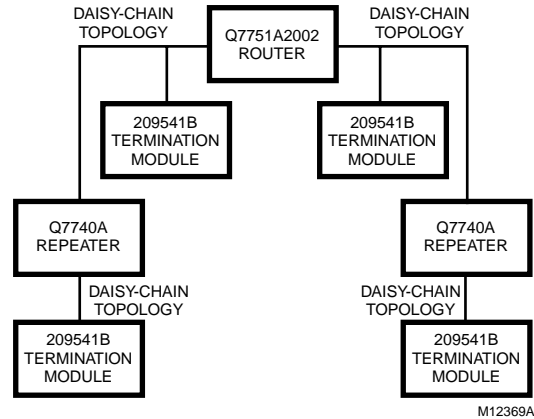

Fig. 2. Repeaters and Router in a FTT network.

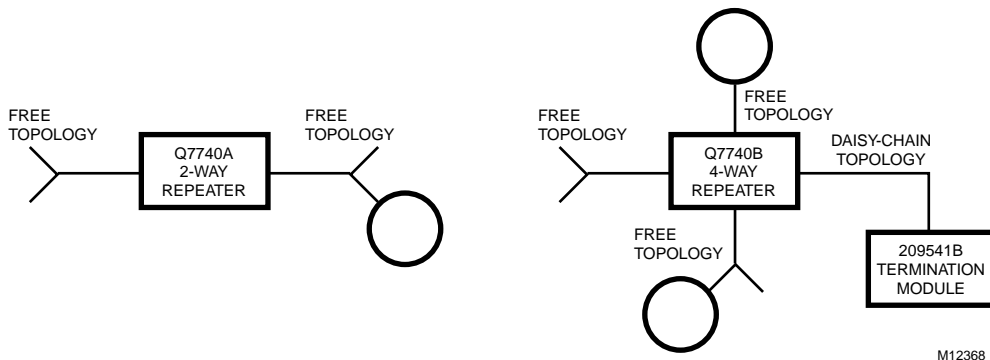

Fig. 3. Physical Layer Repeater (Q7740A 2-Way or Q7750B 4-Way).

NETWORK CABLING AND CONNECTIONS

This section provides information about cabling and FTT network connections.

IMPORTANT

- For network terminal connections, twist the wires together a minimum of three times.
- Only use approved wire and do not use different wire types on the same bus.
- Follow the bus length limits for the cable type used.
- Properly install the 209541B FTT Termination Module, see Fig. 4 through 7.

System Performance and Cable Selection

Transmission Specifications

The free topology transmission specifications include two rules which must both be met for proper system operation:

1. The distance from each device to all other devices and to the termination must not exceed the (singly terminated) *maximum node-to-node (device-to-device) distance*. For example, if multiple paths exist, using loop topology, then use the longest path for the calculations.
2. The *maximum total wire length* is the total amount of wire connected per LONWORKS Bus segment.

NOTE: See Table 1 for daisy-chain doubly terminated FTT network bus topology transmission specifications and Echelon® cable parameters.

Table 1. Daisy-chain FTT Network Bus Topology Transmission Specifications (Doubly Terminated).

Wire/Cable Type (Unshielded)	Cable Parameters				Maximum FTT Network Bus Length for Segment(s)
	C nF/km	Vprop% of c	AWG/Dia.	RloopW/km	
Belden 85102 (stranded non-plenum)	56	62	16/1.5mm ²	28	8900 feet (2700m)
Belden 8471 (stranded non-plenum)	72	55			
Level IV Cable Specifications, 22AWG (solid/stranded twisted pair)	49	67	22/.34mm ²	106	4600 feet (1400m)
TIA568A Category 5 24 AWG (twisted pair solid or stranded, plenum or non-plenum)	46	58	24/.27mm ²	168	3000 feet (900m)

NOTES:

- See Table 2 for singly terminated FTT network bus topology transmission specifications.
- See Tables 3 and 4 for a list of Honeywell provided FTT daisy-chain and free topology network wire/cables.
- See the generic cable manufacturer information that meets Echelon LonWorks Bus specifications in Table 5.

Table 2. FTT Network Free Topology Transmission Specifications (Singly Terminated).

Wire/Cable type (Unshielded)	Maximum Length for Segment(s)	
	Node-to-Node	FTT Network Bus
Belden 85102 (stranded non-plenum)	1640 feet (500m)	1640 feet (500m)
Belden 8471 (stranded non-plenum)	1300 feet (400m)	
Level IV Cable Specifications, 22AWG (solid/stranded twisted pair)		
TIA568A Category 5 24 AWG twisted pair (solid or stranded, plenum or non-plenum)	820 feet (250m)	1500 feet (450m)

Table 3. Honeywell Provided Daisy-Chain (Doubly Terminated) FTT Network Wire/Cables.

Wire/Cable Type (Stranded Unshielded)	Maximum FTT Network Bus Length for Segment(s)
Paige AK3797 - plenum (one twisted pair)	4600 feet (1400m)
Paige AK3799 - plenum (two twisted pair)	
Paige AK3798 - non-plenum (one twisted pair)	

Table 4. Honeywell Provided Free Topology (Singly Terminated) FTT Network Wire/Cables.

Wire/Cable Type (Solid Unshielded)	Maximum Length for Segment(s)	
	FTT Network Bus	Node-to-Node
Paige AK3797 - plenum (one twisted pair)	1640 feet (500m)	1300 feet (400m)
Paige AK3799 - plenum (two twisted pair)		
Paige AK3798 - non-plenum (one twisted pair)		

NOTE: Paige Electric (www.paigeelectric.com) is the recommended manufacturer of network wire.

