

Application

Specifically designed for mechanical room, factory floor, and other similar environments, the JACE-5 is ideally suited for systems integrators that require a rugged and compact controller that can be either wall- or enclosure-mounted, depending on site requirements

On a small building, a single JACE-5 controller can be used to support a network of BACnet and LonWorks devices for access directly over an Ethernet LAN, or remotely over the Internet or via auto-dial modem.

On larger buildings or multi-building complexes and large-scale control system integrations, the Niagara Web Supervisor, in combination with one or more JACE-NPs and/or JACE-5 controllers, manages global control functions, supports global data passing, and hosts multiple, simultaneous client workstations connected over the LAN, the Internet, or via dial-up access.



Note A JACE-5 does not support Database Services. Either disable data archival, or set it to archive remotely.

Models

In total, there are 8 models of the JACE-5, within two distinct groups of 4 models each, as follows:

- **JACE-50x series** (special order only)—Each model has 64MB RAM and 8MB flash memory; two models include the Web User Interface Service (WebUI) and have an additional 8MB SmartMedia flash memory. The 501 has two serial (RS-232/RS-485) ports; the 502 has four serial ports.
- **JACE-51x series** (current platform)—Each model has 128MB RAM and 40MB total flash memory. Two models include the Web User Interface Service. The 511 has two serial (RS-232/RS-485) ports; the 512 has four serial ports.

The newer JACE-51x series have increased capacity for station database and Niagara module storage, and use the Insignia Jeode™ JVM for more efficient station operation. Niagara release 2.3 or later is required.

The original JACE-50x series are compatible with Niagara releases 2.1 through 2.3.5. If installed with Niagara release 2.3 or higher, the JWorks™ JVM is still used, but the JACE becomes job-compatible with newer models.

Table 1 provides a matrix of features and communications ports available on the various JACE-5 models.

Table 1 JACE-5 controller model feature matrix.

Model	RAM	Flash	Ethernet	LonWorks	RS-232 ¹	RS-485	WebUI	Niagara Release	JVM
JACE-501	64MB	8MB	10/100BT	FTT-10	1 or 2	1 ¹ or none	No	2.1, 2.2, 2.3, 2.3.4, 2.3.5	JWorks™
JACE-501-UI	64MB	16MB	10/100BT	FTT-10	1 or 2	1 ¹ or none	Yes		
JACE-502	64MB	8MB	10/100BT	FTT-10	2	2 ²	No		
JACE-502-UI	64MB	16MB	10/100BT	FTT-10	2	2 ²	Yes		
JACE-511	128MB	40MB	10/100BT	FTT-10	1 or 2	1 ¹ or none	No	2.3, 2.3.4, 2.3.5	Jeode™
JACE-511-UI	128MB	40MB	10/100BT	FTT-10	1 or 2	1 ¹ or none	Yes		
JACE-512	128MB	40MB	10/100BT	FTT-10	2	2 ²	No		
JACE-512-UI	128MB	40MB	10/100BT	FTT-10	2	2 ²	Yes		

1. All RS-232 ports and any shared RS-485 port are *not* electrically isolated. See "Power Wiring," page 14, and "Serial," page 16.
2. These RS-485 ports are electrically isolated.

Included in this Package

Included in this package you should find the following items:

- a JACE-5
- JACE-5 Installation and Configuration Instructions
Part Number 10036, Rev. 5 Revised: May 10, 2004
- a **packing slip**, which lists the factory settings for IP address, machine name, and host logon.
- a hardware bag containing the following items (note the power connector is pre-wired to the battery):
 - 3-position RS-485 screw terminal connector plugs, quantity 2 if JACE-5x2 (one if JACE-5x1).
 - 2-position LON screw terminal connector plug.

Precautions

This document uses the following warning and caution conventions:



Caution

Cautions remind the reader to be careful. They alert readers to situations where there is a chance that the reader might perform an action that cannot be undone, might receive unexpected results, or might lose data. Cautions contain an explanation of why the action is potentially problematic.



Warning

Warnings alert the reader to proceed with extreme care. They alert readers to situations where there is a chance that the reader might do something that can result in personal injury or equipment damage. Warnings contain an explanation of why the action is potentially dangerous.

Safety Precautions

The following items are warnings of a safety nature relating to the installation and start-up of the JACE-5 controller. Be sure to heed these warnings to prevent personal injury or equipment damage.



Warning

-
- **A 24Vac, 50/60 Hz circuit powers the JACE-5 controller. Disconnect power before installation or servicing to prevent electrical shock or equipment damage.**
 - **Make all connections in accordance with national and local electrical codes. Use copper conductors only.**
 - **To reduce the risk of fire or electrical shock, install in a controlled environment relatively free of contaminants.**
 - **This device is only intended for use as a monitoring and control device. To prevent data loss or equipment damage, do not use it for any other purpose.**
-

Static Discharge Precautions

The following items are cautionary notes that will help prevent equipment damage or loss of data caused by static discharge.

**Caution**

- Static charges produce voltages high enough to damage electronic components. The microprocessors and associated circuitry within a JACE-5 controller are sensitive to static discharge. Follow these precautions when installing, servicing, or operating the system.
- **Work in a static-free area.**
- **Discharge any static electricity you may have accumulated. Discharge static electricity by touching a known, securely grounded object.**
- **Do not handle the printed circuit board without proper protection against static discharge. Use a wrist strap when handling PCBs. The wrist strap clamp must be secured to earth ground.**

Installation and Start-up

There are four major steps to installing and starting the JACE-5, as outlined below:

1. [Unpack the JACE-5](#)
2. [Install the JACE-5](#)
3. [Upgrade, License, and Configure the Host](#)
4. [Install the Station Database and Start the Station](#)

Please read through the entire document before beginning the installation procedure.

Unpack the JACE-5

Unpack the JACE-5 and inspect the contents of the package for damaged or missing components. If damaged, notify the appropriate carrier at once and return any damaged components for immediate repair or replacement. See [“Returning a Defective Module”](#) on page 27.

Install the JACE-5

Installing the JACE-5 has five major steps, as outlined below:

1. [Physical Installation](#)
2. [Review Power Requirements](#)
3. [Make Connections](#)
4. [Power Up and Initial Checkout](#)
5. [Connect to the JACE-5](#)

Physical Installation

Tools Required

The following tools and supplies may be required for installation:

- 1/4-inch nut driver used to remove the battery bracket and work with the ground lug.
- A screwdriver and pliers used to loosen and remove the conduit knockout.
- A small (1/8-inch flat blade) screwdriver to work with the screw terminals on the communications wiring and secure the DB-9 connectors to their strain relief.

Mounting

Mount the JACE-5 controller in a location that allows clearance for wiring, servicing, and module removal. See the “[Mounting Detail](#),” page 19 and “[Drill Template](#),” page 20.

Pay attention to the following recommendations and precautions when mounting and installing the unit.

- This product is intended for indoor use only. The unit should not be exposed to ambient conditions outside of the range of 0°C (32 degrees F) to 50°C (122 degrees F) and relative humidity outside the range 5% to 95% non-condensing.
- If the controller is mounted inside an enclosure, that enclosure should be designed to keep the unit within its required operating range considering a 20-watt dissipation by the controller. This is especially important if the controller is mounted inside an enclosure with other heat producing equipment.
- See [Figure 3](#) on page 19 for proper mounting clearances. Minimum clearance from the wall on which the unit is mounted is 0.2-inches (provided by the dimpled mounting feet). Ensure that this space is not compromised and that airflow is not blocked behind the unit.
- Do not mount the unit:
 - in an area where excessive moisture, corrosive fumes, or explosive vapors are present.
 - where vibration or shock is likely to occur.
 - in a location subject to electrical noise. This includes the proximity of large electrical contactors, electrical machinery, welding equipment, spark igniters, etc.
- The unit is designed to be wall mounted with the battery situated towards the top of the unit. For proper airflow at temperature extremes, do not mount the unit oriented in any other way.

Installing the Cover

The JACE-5 cover provides side latches (left and right) that fit into slots on the metal backplate of the unit and a security screw that secures the cover in place (situated at the top of the unit, just off-center).



Note The security screw that ships with the JACE-5 is a standard #10-32 machine screw, pan head, 1/2-inch Phillips. You can replace this screw with a tamper-proof screw to provide a more secure installation.

Removing the cover—To remove the cover of the JACE-5, loosen the security screw, push in the side latches (left and right) approximately 1/2-inch, and lift the cover away from the controller, towards you.

Replacing the cover—To replace the cover, ensure the security screw (if used) on the top of the unit is loosened (backed off about 1/4-inch). Align the side latches to their corresponding slots in the metal backplate and make sure there is enough clearance to slide the cover under the security screw. Putting inward pressure on the side latches, push the cover into place. Release the side tabs and verify that they latch securely into place. Tighten the security screw.

Review Power Requirements

Power wiring is to be made to a UL listed, Class 2, 24Vac transformer, with a minimum rating of 20VA.

- A dedicated transformer for each JACE-5 is required. See the related [Warning](#) on page 14.
- Connections should be made in accordance with national and local electrical codes. Use copper conductors only.
- Neither side of the transformer's secondary winding should be connected to earth ground or building neutral. See the [“Power Wiring”](#) section on page 14 for cautions that include more details.

Make Connections

Make connections to the JACE-5 in the following order. For specific details on each step, refer to the [“Wiring Details”](#) section on page 14.

1. With the 5-position power connector disconnected from the board, wire the 24Vac power to the power connector.
2. Connect the Ethernet cable.
3. Connect any other communication cables.

See [Figure 1](#) to locate connectors and other components on the JACE-5 controller.

Power Up and Initial Checkout



Note As referenced above, the Ethernet connection must be made prior to applying power to the controller.

Ensure power wiring to the transformer has been completed before proceeding (see the [“Power Wiring”](#) section on page 14). The JACE-5 controller does not include an on/off switch. To apply power, insert the 5-position power connector plug.

Refer to [Figure 1](#) on page 18 for the locations of the connectors, status LEDs, and other components on the JACE-5 controller.

Checking the Heartbeat LED

When power is first supplied to the controller, the red heartbeat LED will come on solid for approximately 10 seconds, then begin to blink. The blink pattern of the heartbeat LED under normal operation will differ for each installation (depending on station activity). In general, the LED should blink about once per second. The rate will be slower when the control engine is executing the station database and as more objects are added.

If the heartbeat LED does not light when power is applied, check the 24Vac voltage at the power connector.

After applying power to the controller, if the heartbeat LED comes on (steady) and stays lit longer than two minutes, contact Systems Engineering for technical assistance. See the [“About Status LEDs”](#) section on page 22.

About the Battery

The JACE-5 is provided with a sealed lead acid battery, which is nearly fully charged. Therefore, the JACE-5 has battery back up protection immediately upon installation. If battery trouble messages are generated upon power up, contact Systems Engineering for technical support.



Caution In the event of battery trouble messages, ensure the station database is backed up to removable storage such that it can be restored in the event of a power failure and loss of data.

For more information on the use and replacement of the battery, refer to the “[Field Replacement Units](#)” section on page 25.

Connect to the JACE-5

These instructions assume that you have a PC installed with the Niagara Web Supervisor software, which includes the Java Desktop Environment (JDE) and the host administration tool (Admin Tool). This PC will be referred to as “your PC”.



-
- Notes**
- You should use the same Niagara release level on your PC that you want to run in the JACE-5.
 - Release 2.3 or later is *required* for JACE-511 and JACE-512 models. In the following procedures, release 2.3.5 is referenced because it applies to all JACE-5 models.
 - As needed by the installation, JACE-501 and JACE-502 models can be configured using any Niagara release level from 2.1 to 2.3.5.
-

Once the JACE has powered up, you should connect to the JACE with the Admin Tool to assign it a unique IP address and other network settings to be used for communications. In addition, you must set current host date, time, and time zone since the JACE-5 is shipped with the battery disconnected.

Also, it is strongly recommended that you change the password for the default administrator-level host user account (tridium)—see the related [Caution](#) on [page 10](#) for more details.

The JACE-5 controller is pre-configured with an IP address in the range 192.168.1.14x, and a default subnet mask of 255.255.255.0.



-
- Notes**
- The IP address is listed on the packing slip that accompanies the unit.
 - Make sure the PC that you use to access the JACE-5 during installation is assigned an address in the range: 192.168.1.1 to 192.168.1.254, with a subnet mask of 255.255.255.0.
-

Changing Networking Properties

You can use the Admin Tool from your PC to access all Niagara hosts including remote JACE-5s. In addition to station-related operations (i.e., starting and stopping stations, archiving station data, importing and exporting configuration databases, and so on), the Admin Tool allows you to change operating system parameters on the JACE-5. These changes include editing host name, TCP/IP networking properties, and setting time, date, and time zone. The reboot function allows you to restart a JACE-5 remotely to implement changes.

The right half of the Admin Tool window provides access to operating system parameters for the selected host. Four tabs are available: the Summary tab, the Network Settings tab, the Users tab, the System Time tab, DbAdmin tab, and the Installation tab.

The Networks Settings tab provides access to the selected host's networking properties, including host name (computer name) and the TCP/IP properties listed below (each property must be obtained from your Network Administrator). Use the **Apply** button to store any changes you make (note that changes are not effective until the host is rebooted). The **Reset** button restores changes since the last **Apply**.

- **Computer Name**—The name you want to use for this host.
- **DNS Domain**—The TCP/IP Domain Name System (DNS) domain this host belongs to, if used.
- **IP Address**—The unique Internet Protocol (IP) address for this host.
- **Subnet Mask**—The IP subnet mask used by this host.
- **Default Gateway**—The IP address for the device that forwards packets to other networks or subnets.
- **Hosts File**—A text file used by TCP/IP to associate host names with IP addresses.
- **DNS Servers**—The IP address for one or more DNS servers, each of which can automate associations between host names and IP addresses. The Add, Delete, Modify, and Up/Down buttons in the Admin Tool window can be used as needed to reference the DNS server IP addresses and set DNS search order.



Note If you specify a DNS server, you must provide a domain name for this host in the DNS Domain field. Otherwise, the DNS function will not work.

Use the following procedure to set the IP address of the new JACE-5.

Procedure 1 Setting the IP address on a new JACE-5.

Step 1 If not already installed, load the **Vykon R2.x Web Supervisor** software on your PC, including its permanent license.

Step 2 Attach one end of a standard Category-5 Ethernet unshielded twisted pair (UTP) patch cable to the RJ-45 connector on the JACE.

Step 3 Attach the other end of the patch cable to a network port or directly to an Ethernet hub.



Tip Instead of a hub, you can use an Ethernet crossover cable to connect the JACE-5 directly to the Ethernet port on your PC. For more information about crossover cables, see the “About Ethernet Straight Through and Crossover Cables” in the *Niagara Networking & Connectivity Guide*.

Step 4 Power up the JACE.



Note If the controller is powered on prior to making the Ethernet connection, the unit may not be accessible on the network. With the Ethernet cable plugged in, disconnect the 5-position power connector, allow the controller to completely power down (no blinking status LEDs), and reconnect the power connector.

Step 5 Assign the IP address of your PC in the range of 192.168.1.1 to 192.168.1.254. However, do not duplicate the IP address already assigned the JACE-5 or another host on the LAN.

- Step 6** From your PC, start the **Admin Tool**.
- Click the **Start** button on the **Taskbar** and expand the **Programs** menu to view the **Niagara** folder.
 - Click the **Admin Tool** icon to launch the **Admin Tool**.
- Step 7** In the **Admin Tool** view, click **File** on the menu, and click **Open**.
A connection dialog is displayed.
- Step 8** Type the pre-assigned IP address of the JACE-5 and click **OK** (see the previous section [“Connect to the JACE-5”](#)).
- Step 9** Log onto the JACE-5 controller with default logon user name and password, as it appears on the packing list. Typical defaults are: user name = **tridium** and password = **niagara**. Click **OK**.
The JACE-5 controller (IP address) appears in the Admin Tool view as an open host.



Note By default, the **Summary** tab is shown first. Among items listed is an “AC Power Status,” which shows “ok” if the 24Vac power is good. If the JACE loses this power (and is running on its battery), this status shows “failed.” See also [“Configure Power Shutdown Options,”](#) page 11.

- Step 10** Click the **Network Settings** tab.
- Step 11** Assign the JACE-5 a unique IP address and other network settings to be used for communications, as described above.



Note Once you have made changes to one or more network settings, you must reboot the host for those changes to be implemented.

- Step 12** From the menu, select **Admin Tool > Host > Reboot** to implement your changes.
The JACE is now accessible using the IP address you assigned it (and not the default IP address).



Note An **ipchanges.txt** file is created or updated in the <x>:\niagara\<release>\nre\user directory on your PC whenever you change the IP address of a host using the Admin Tool (release 2.2 or later). If needed, you can refer to this file to see the new (and previous) IP address.

Setting Host Date and Time

Use the **System Time** tab of the Admin Tool to access the host's system time, date, and time zone. To change the settings, click on the information you want to change and type the new information. When finished, click **Apply**. Changes you make in these settings become immediately effective on the host.

Configuring Host Users

Use the **Users** tab of the Admin Tool to access host user accounts on the JACE-5. The top area shows current user accounts, which you select by clicking on the user name. A selected user can be deleted, or have password and/or groups assignments modified (available user groups are accessed in the lower area).

**Caution**

It is strongly recommended that you change the password for the default, administrator-level, *host* user account (tridium) upon installation. This account cannot be deleted. Signing on as the “tridium” administrator allows you to modify *all* host user accounts.

**Note**

Be aware that after you modify this administrator user and you then lose or forget the new password, you must contact Systems Engineering for a procedure to regain administrative host access.

You can also add a new user. This produces a New User dialog to establish the User Name and Password. By default, a new user is not assigned to any user group(s); you need to check the Administrator group assignments in order for the user to use the JDE Admin Tool.

Use the **Apply** button to store any modifications, which become effective immediately. The **Reset** button restores changes since the last Apply.

Upgrade, License, and Configure the Host

This step consists of three main tasks:

1. [Install the Software](#)
2. [Configure Power Shutdown Options](#)
3. [Install the Station Database and Start the Station](#)

Install the Software

Each JACE-5 controller is shipped with the Wind River VxWorks™ operating system and the appropriate JVM (Java™ virtual machine). However, the Niagara Runtime Environment (NRE) software, and the Niagara service (NIAGARAD) are not installed and you must install them.

Use the following procedures to install the software. Consult the *Niagara Release 2.3.5 Installation & Upgrade Instructions* for more information, including “Upgrade Considerations for the JACE-5 Platform.”

**Caution**

If upgrading a JACE-501 or -502 running release 2.1 or 2.2 to a later release, be aware that you cannot “downgrade” back to the older release without first performing a series of steps using an FTP connection. For more details, consult with Systems Engineering. Also, see the last [Note](#) on page 11.

These procedures assume that you have successfully tested connectivity to the JACE-5 and can access the unit over the Ethernet LAN.

Procedure 2 Installing the software.

Step 1 Using Windows Explorer, copy the **emb** and **nt** directories from the R2.3.x installation CD to the following directory on the hard drive of your PC:

```
<x>:\niagara\<release>\
```

where <x>: is the drive where you installed Vykon, and <release> is the Vykon release you installed in [Step 1 of Procedure 1](#).

- Step 2** Using the **Admin Tool**, connect to the JACE-5 as described in [Procedure 1](#).
- Step 3** Click the **Installation** tab.
- Step 4** On the **Installation** view, click the **Installation Wizard** button.
- Step 5** In the **Select Distribution Directory** dialog, select **emb** and click the **Install** button.
- Step 6** In the **Niagara Remote Installation** dialog, click the radio button for **Upgrade**, then click **Next**.
- Step 7** In the **Upgrade** dialog box, click check boxes for **Upgrade OS** and **Upgrade NRE**, then click **Next**.



Note You must upgrade niagrad when you upgrade the OS.

- Step 8** In the **Configure Modules** dialog box, click inside the **Upgrade/Add** column for each module licensed for installation on the JACE-5.

A red check mark appears for each selected module.



Note The JACE-5 has limited memory resources (software modules run out of flash memory rather than a hard disk). Therefore, select only those modules that are required for station operation. If you are unsure about the software modules that have been purchased and licensed for the JACE-5, check the license by clicking **View License** on the **Installation** tab of the **Admin Tool** view.

- Step 9** Click **Next** to continue.
- Step 10** On the **Database Backup** dialog box, click the red check mark next to the database name and click **Next** to continue. (It is not necessary to back up any test station database pre-installed on the JACE-5.)
- The **Niagara License** dialog box opens. The JACE-5 is shipped with the license file already installed.
- Step 11** On the **Niagara License** dialog box, click **Finish**.
- A text box displays the tasks selected for the software upgrade.
- Step 12** Click **OK** to continue.
- A dialog displays each task as it is performed. Depending on the number of tasks to be performed, the process may take from one to three minutes.
- Step 13** When complete, click **OK**.



Note A JACE-5 running 2.3 or later requires the following line in its **drivers.properties** file to avoid a startup error: `driver.sysmon=tridium.nre.drivers.SysMonDriver`

If upgrading from an earlier release, manually add this line to **drivers.properties** using [Procedure 3](#).

Configure Power Shutdown Options

If desired, you can change the operation of JACE-5's "power monitoring/shutdown" mechanism by editing the **drivers.properties** file. Any changes to this file requires a station restart (host reboot) to become effective.

Table 2 lists power shutdown parameters for the JACE-5 found in `drivers.properties`. For additional information, please refer to the Engineering Notes document *Niagara System and Power Monitoring*.

Table 2 JACE-5 power shutdown parameters in the `drivers.properties` file.

Parameter, Default Value	Description
<code>power.enabled=true</code>	<p>Enables the power driver, which provides graceful shutdown of the JACE on AC power loss. When set to true, the next two parameters apply. When set to false:</p> <ul style="list-style-type: none"> the JACE does not monitor the A/C power on power loss, the JACE runs on battery until it is drained (unless AC power is restored). <p>Note: You should leave this value set to true.</p>
<code>power.pollRate=15</code>	<p>The rate (in seconds) that the power monitor of the JACE waits before checking for A/C power loss. The monitor wakes up every <code>pollRate</code> seconds, checks the A/C power status, then goes back to sleep (if the power status is OK). However, if the JACE has lost A/C power, the monitor generates a <i>station</i> alarm and starts the shutdown timer.</p> <p>Station alarms are sent to the Station object's <code>notificationClass</code>.</p>
<code>power.shutdownDelay=60</code>	<p>Number of seconds the JACE waits between detecting the loss of A/C power and performing a graceful shutdown (where the JACE does a database backup and turns the board off). Typically, the default value is recommended. You can increase this time, however, this means more time running on battery power. In this case, if multiple lengthy power failures occur in succession, the battery may become completely discharged.</p> <p>If a station is <i>not</i> running, the JACE runs from the battery for 5 minutes before shutdown.</p>
<code>power.batteryTestRate=15</code>	<p>Number of minutes between the periodic testing of the backup battery under a simulated load. Default (and <i>minimum</i> recommended) value is 15 minutes.</p> <p>When the test runs, a 900mA load is placed on the battery for less than one second. If the voltage drops below a predefined value, then the "battery test failed". If the voltage is higher, then the "battery test passed".</p> <p>A station alarm is generated <i>only</i> when the new outcome is different than the previous test. If a battery is marginal, the test may go from "failed" to "passed", and then "failed" again.</p>

Use the following procedure to view or edit the `drivers.properties` file.

Procedure 3 Viewing or editing the `drivers.properties` file.

-
- Step 1** Using the **Admin Tool**, connect to the JACE-5 as described in [Procedure 1](#).
- Step 2** On the **Installation** tab, click **Edit drivers.properties**.
The `drivers.properties` file opens in a text editor.
- Step 3** Make any changes to the text of the file.
- Step 4** From the file menu, choose **File > Close**.
If you made any changes, you are prompted to save them, otherwise the window closes.
- Step 5** If prompted to save your changes, click one of the following:
- Yes** to save your changes. The file saves and the window closes.
 - No** to discard your changes. The window closes.
 - Cancel** to return to the editing window, then refer to [Step 3](#).
- Step 6** From the menu, select **Admin Tool > Host > Reboot** to implement your changes.
-

Install the Station Database and Start the Station

This step assumes that you have created a station database on your PC and need to install that database onto the JACE-5. Use the following procedure to install a previously created station on the new JACE-5.



Note Installing a station from your PC places everything in your local station database folder (<x>:\niagara\<release>\stations\<stationname>) onto the JACE-5. Since the JACE-5 has limited memory resources, you should limit what is in your local station database folder so you do not exhaust the resources on the JACE.

Procedure 4 Installing and starting a station.

-
- Step 1** As described in [Procedure 1](#), open the **Admin Tool** and connect to the JACE-5.
- Step 2** Click the **Installation** tab.
- Step 3** On the **Installation** tab, click the **Install Station** button.
- Step 4** From the list of available stations on your PC, choose the desired station and click **OK**.
- Step 5** Verify your intent to overwrite the existing database by clicking **Yes**.
- Step 6** If more than one version or format of the station database exists on your PC, select the one that you intend to install and click **OK**.
- A progress dialog displays tasks as it completes them. These messages indicate when the installation wizard is converting the database, starting maintenance, and reconnecting to the station.
- Step 7** When the installation wizard indicates that it is complete, click **OK**.
- The installation wizard automatically starts the station. Therefore, you should not have to perform this step separately. However, if the status of the station shows 'idle', use the next step to start the station on the JACE controller.
- Step 8** From the **Admin Tool** view, click the station name and click the **Start** button  on the toolbar. Verify that the status of the selected station updates to **running**.
-

Wiring Details

This section includes details on [Power Wiring](#) and [Communications Wiring](#).

Power Wiring

Read the “[Review Power Requirements](#)” section on page 6.



Warning

Verify that neither side of the transformer’s secondary winding is connected to earth ground or building neutral, and that the JACE-5 is the only device powered by that transformer.

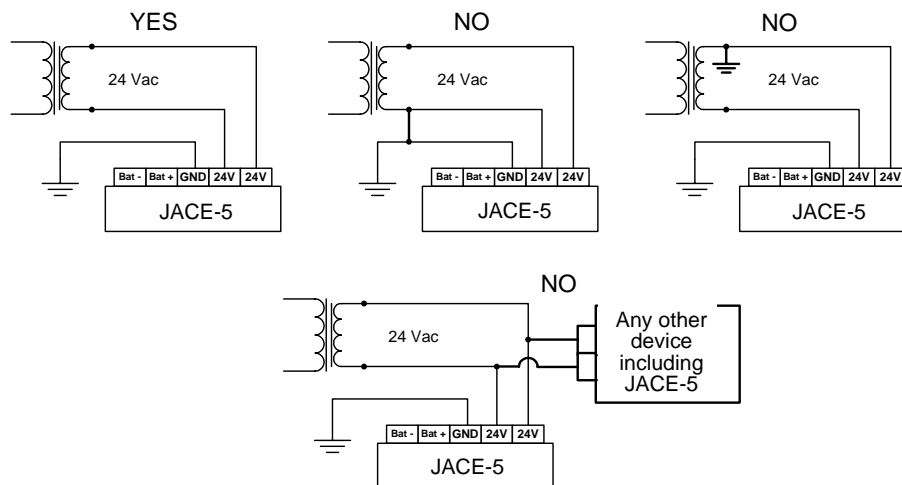

Otherwise, exposure to ground loop problems (described below) is increased, and permanent damage to the JACE-5 and/or other attached equipment may occur.



Warning

Please be aware that a JACE-5 may experience ground loop problems resulting in equipment damage, and/or minimally communications problems, in any of the following scenarios:

- **Another piece of equipment is powered by the same transformer, and it is connected to earth ground or a common reference, including through its RS-232 or RS-485 port. (Most equipment has some sort of ground reference if it has communications ports.)**
- **Multiple JACEs are powered by the same transformer, and one JACE's RS-232 or RS-485 port is connected to one device and then another JACE's RS-232 or RS-485 port is connected to another device.**
- **One side of the transformer secondary powering the JACE is wired to earth ground (or some other common reference), and the RS-232 or RS-485 port of the JACE is then connected to an earth-grounded device.**
- **A JACE-501 or -511, where the RS-232 port is connected to an earth-grounded device and the RS-485 port is also connected to grounded equipment. In this application, a JACE-502 or -512 is required for proper isolation of the RS-485.**

Power Connections

Located at the top, right edge of the controller is a 5-position power connector. From left-to-right, power connector terminals are labeled:

BATT (-)	BATT (+)	GND	24Vac	24Vac
----------	----------	-----	-------	-------



Caution

The screw terminals of the power connector are not fully accessible with the connector plugged in. Do not attempt to tighten or loosen screw terminals with the connector plugged in. Attempting to tighten or loosen these screw terminals without unplugging the power connector may cause a short circuit between the terminal and the chassis.

Unplug the power connector from the JACE-5 and make connections to its as shown in [Table 3](#).

Table 3 JACE-5 power connector terminals.

24Vac	One side of the 24Vac transformer
24Vac	Other side of the 24Vac transformer
GND	Building/Earth ground (green wire)
BATT (+)	Positive (+) terminal of 12Vdc battery (red wire)
BATT (-)	Negative (-) terminal of 12Vdc battery (black wire)

Communications Wiring

All communications wiring is made from the bottom edge of the controller. Strain relief should be employed to prevent damage caused to the controller if there is stress put on the communications wiring.

The following sections cover communications wiring:

- [Ethernet](#)
- [Serial](#)
- [LonWorks \(LON\)](#)

Ethernet

A single, female RJ-45 (8-wire) connector provides a 10/100-Mbit Ethernet connection. This connection is capable of running at either 10 Mbps or 100 Mbps—it automatically adjusts to either speed. This means the JACE-5 can exist on the same network with a mixture of 10BaseT and 100BaseTX hardware connected to a smart 10/100 hub capable of adjusting to the devices it supports.

Using a Category 5 unshielded twisted pair (UTP) cable, connect one end of the cable to the RJ-45 connector on the JACE, and the other end to a hub on the Ethernet LAN. The maximum end-to-end distance from the controller to the hub is 328 feet (100m).



Note

The JACE-5 controller identifies itself to the Ethernet LAN during power up. If the controller is powered on prior to making this connection, the unit will not be accessible on the network. With the Ethernet connector plugged in, disconnect the 5-position power connector, allow the controller to completely power down (no status LEDs are blinking), and reconnect the power connector.

Serial

Depending on model type, a JACE-5 has either two (2) or (4) available serial ports, as follows:

Table 4 JACE-501 and JACE-511 Serial Ports (only 2 can be used).

Model	RS-232 (DB-9P connectors)		RS-485 ¹ (3-wire screw terminal)	
501, 511	PORT1 (COM1)	PORT2 ² (COM2) <i>or</i> :	PORT1 ² (COM2)	—

1. Not isolated (RS-485 shield “S” terminal is common to signal ground of RS-232 port).
2. Either the RS-232 PORT2 *or* the RS-485 PORT1 can be used, but *not both*.

Table 5 JACE-502 and JACE-512 Serial Ports (all 4 ports are available).

Model	RS-232 (DB-9P connectors)		RS-485 isolated (3-wire screw terminal)	
502, 512	PORT1 (COM1)	PORT2 (COM2)	PORT1 (COM3)	PORT2 (COM4)

RS-232

RS-232 serial port connections are made to the DB-9P (male) connectors located at the bottom edge of the controller. The JACE-5 is a DTE (data terminal equipment) device; a DCE device (data communications equipment, such as a modem) can be connected using a straight-through cable.

A null-modem cable is required to connect to another DTE device (i.e., terminal). Pinouts are shown in [Table 6](#).

Table 6 Pinouts for RS-232 ports on a JACE-5.

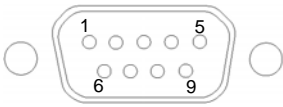
RS-232 DB-9 Pinouts (Industry-standard DTE configuration)			
DP-9P (male) connector	Pin	Name	Description
	1	DCD	Data carrier detect
	2	RXD	Receive data
	3	TXD	Transmit data
	4	DTR	Data terminal ready
	5	GND	Signal Ground (see Note .)
	6	DSR	Data set ready
	7	RTS	Request to send
	8	CTS	Clear to send
	9	RI	Ring Indicator

Note: Signal ground pin 5 is not isolated. This means:

- Pin 5 is common between *both* DB-9 RS-232 connectors.
- If a JACE-501 or -511, pin 5 is common to the shield (S) terminal of the (non-isolated) RS-485 connector.



Note Use only shielded cable for an RS-232 connection, such as available with a standard (pre-fabricated) straight-through or null-modem cable. If fabricating a cable, connect the shield (drain) wire to the DB-9S (socket) connector shell at the JACE end (only)—do not connect the drain wire at the other end.

For more information on RS-232 serial ports and cables, see the “About Serial and Null Modem Cables and Adapters” section of the *Niagara Networking and Connectivity Guide*.

RS-485

RS-485 multi-point connections are made to the 3-position, screw terminal connector plug. Wire to this connector with 18-22AWG shielded cable. Screw terminals (from left to right) are shield, plus (+), and minus (-).



Warning

Depending on various wiring, a ground loop hazard may exist that results in equipment damage to the JACE-5 and/or other RS-485 devices. Before connecting the RS-485 trunk to the JACE-5:

- Review the “**Power Wiring**” section on page 14.
 - Ensure that the RS-485 shield conductor connects to earth ground only at *one end* of the RS-485 trunk (ideally the JACE-5).
-

LonWorks (LON)

A single, two-pin, male LonWorks FTT-10A Weidmuller connection is provided on the controller. This connection supports twisted pair, unshielded, polarity-insensitive, peer-to-peer communications at 78 Kbps.

Refer to the LonWorks FTT-10A Free Topology Transceiver User's Guide (078-0156-01F) for technical guidelines associated with free topology restrictions and the Junction Box and Wiring Guidelines for Twisted Pair LonWorks Networks (005-0023-01) for more detailed information on wiring specifications. These documents are available on Echelon's web site (www.echelon.com).

Figures

The following figures provide details for component layout, and mounting the JACE.

- [Connector Layout](#)
- [Status LED Layout](#)
- [Mounting Detail](#)
- [Drill Template](#)

Connector Layout

Figure 1 Connectors are located on the bottom edge of the JACE-5 controller.



Status LED Layout

Figure 2 LEDs are labeled on the cover and provide system indication. See “About Status LEDs,” page 22.

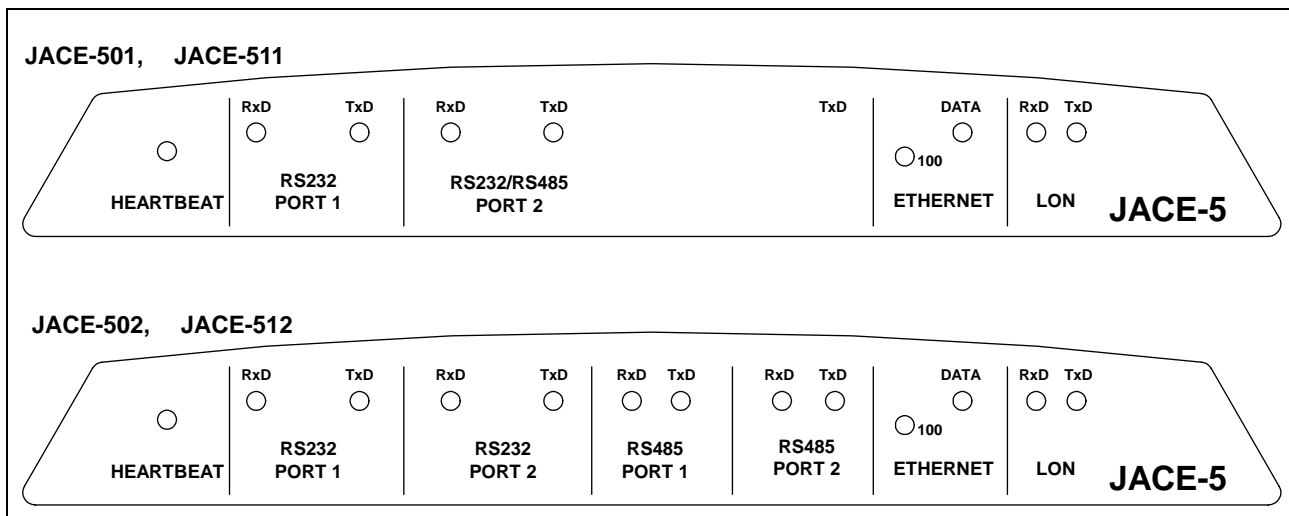

Mounting Detail

Figure 3 Mounting details.

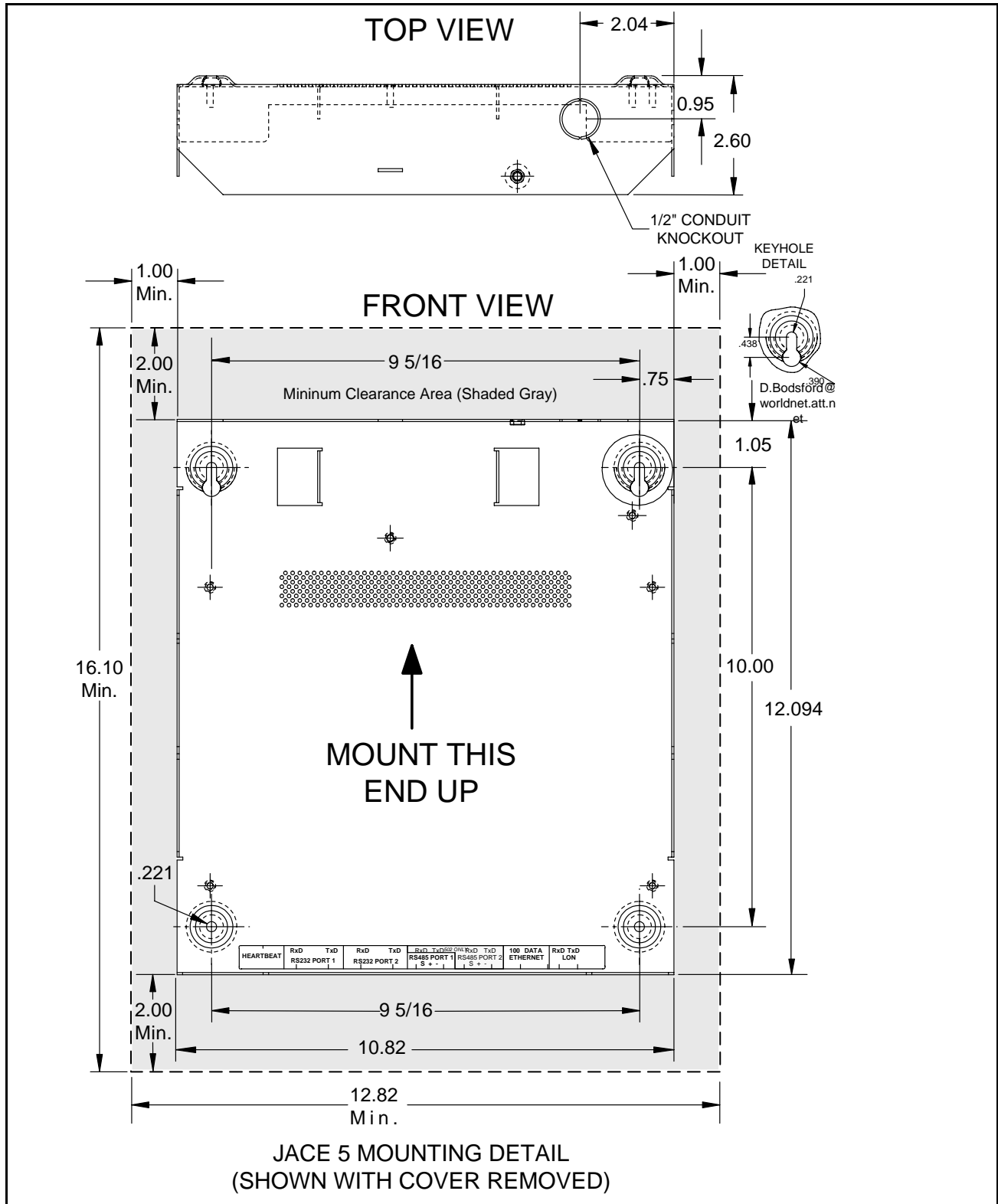



Drill Template



Note

Electronic and printed versions of this document may not show this mounting template to scale.

Verify all measurements before drilling.

Drill Template

Holes are 9 5/16" apart.

Bottom holes are 10.0" below the top holes.

Keyhole for a #10 Pan head screw..

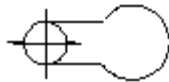

Related Documentation

For more information on configuring and using the JACE-5 controller, consult the following documents available from the secure side of www.tridium.com:

- *Niagara Release 2.3.5 Installation and Upgrade Instructions*
- *Niagara System and Power Monitoring, Engineering Notes*
- *Niagara Networking & Connectivity Guide*
- *Niagara Standard Programming Reference, Release 2.3.5*

About Status LEDs

The JACE-5 controller includes a series of LEDs, visible (and labeled) with the cover installed. From left to right, LEDs include the following: [Heartbeat](#), [Serial Ports](#), [Ethernet Port](#), [LON \(LonWorks\) Port](#). See “[Status LED Layout](#),” page 18, for exact location of LEDs.

Heartbeat

This LED is red. Under normal operation, the heartbeat LED should blink about once per second. The blink pattern will differ as station activity increases, but any pulse rate from once per second to 10 blinks per minute usually indicates normal control engine activity.

If the heartbeat LED stays on constantly or does not light, contact Systems Engineering for technical support.

Serial Ports

Status LEDs for serial ports are located above each RS-232 or RS-485 connector. They show the transmit and receive information for that port. The yellow transmit LED (TxD) indicates that the JACE-5 is *sending* data out the serial port to a connected device. The green receive LED (RxD) indicates that the JACE-5 is *receiving* data from a connected device.

LEDs are driven by pulse detectors that have a fixed on-time when data is detected. If these LEDs are on constantly, this indicates a problem with the communications channel, such as a shorted wire or reversed wiring.

Ethernet Port

Two green LEDs are associated with the Ethernet port, located above the port. The LED marked “100” indicates whether the JACE-5 is operating at 10 Mbps (Ethernet) or 100 Mbps (Fast Ethernet). If the 100 LED is on, the network connection is operating at 100 Mbps. Otherwise, the port is communicating at 10 Mbps.

The LED marked “DATA” indicates activity on the port as follows:

- **Off**—No Ethernet link is made.
- **On**—Ethernet link is present, but no activity on the LAN.
- **Blinking**—Ethernet link is present with data activity on the LAN.

LON (LonWorks) Port

Two LEDs are located above the LON port, and show transmit and receive activity. The yellow transmit LED (TxD) indicates that the JACE-5 is *transmitting* a message on the LonWorks trunk. The green receive LED (RxD) indicates that another LonWorks device is transmitting a message on the wire.

Maintaining the JACE-5

This section provides information on the following topics:

- [Cleaning](#)
- [Required Battery Maintenance](#)
- [Replacement Parts](#)
- [Returning a Defective Module](#)

Cleaning

If dust or metal filings are present inside the unit, clean with vacuum or compressed air. Otherwise, no cleaning inside the unit is required. Optionally, if the cover becomes dirty, you can wipe it with a damp cloth and mild detergent.

Required Battery Maintenance

Battery life expectancy is a function of its discharge cycles (the number of discharges and their depth) and the ambient temperature of the battery during normal operation. In most applications, the battery should see relatively few discharges. Therefore, ambient temperature has more to do with determining the life expectancy of the battery than does any other factor. If the JACE-5 is installed in a conditioned space, the battery should provide dependable service for approximately three years (average). In an environment where the operating temperature is higher (i.e., 50°C or 122°F), you should only expect the battery to last approximately one year.

The sealed lead acid battery in the JACE-5 controller is nearly fully charged before shipping. The battery is automatically float-charged during normal operation (while power is applied to the unit). The JACE-5 monitors the battery and periodically loads the battery to test its ability to maintain battery-backed functions. You should investigate any battery trouble message. Check the voltage level and its connections to the unit. Replace the battery as required.

To order a new battery, see the “[Standard Replacement Parts](#)” section on page 25.

Replacing the Battery



Warning

When replacing the battery or harness, maintain proper polarity as marked on the label inside the unit. Although the JACE-5 is fully protected against shorted battery terminals, the battery itself is not internally protected. Use extreme care to not short circuit the battery. A shorted battery may overheat rapidly and damage the power wiring harness or cause other physical harm to the hardware.

To replace the battery, proceed as follows:

Procedure 5 Replacing a JACE-5 battery.

- Step 1** Turn off building power to the JACE-5.
- Step 2** Unplug the 5-position power connector. Do not remove the male connector from the wiring harness.
- Step 3** Using a 1/4-inch nut driver, unscrew the lock nut from the bracket that is holding the battery. Hold the battery in place while you remove the bracket that secures it to the backplate.
- Step 4** Disconnect the two quick connect terminals on the battery.



Note The JACE-5 will lose its time and date settings if it is disconnected from both battery and AC power for more than one hour.

- Step 5** Remove the old battery and recycle as defined by your regional codes. For recycling within the US, see the labelling on the battery.
- Step 6** Connect the quick connect terminals to the new battery. Make sure the RED (+) wire is connected to the positive terminal of the battery and the BLACK (-) wire is connected to the negative terminal.
- Step 7** Secure the new battery to the backplate with the bracket and tighten the lock nut.
- Step 8** Plug the power connector in.
- Step 9** Restore building power to the JACE-5 and verify normal operation.
-

Replacement Parts

Servicing the JACE-5 may call for replacement parts. There are three categories of parts:

- [Non-replaceable Parts](#)
- [Standard Replacement Parts](#)
- [Field Replacement Units](#)

Non-replaceable Parts

Other than parts listed in the replacement parts sections, no serviceable components exist on the base assembly.

Memory

Any addition, modification, or replacement of memory components requires software configuration and is not a field upgrade. For additional information on modifying the memory capacity of the JACE-5, consult Systems Engineering for technical support.

Fuses

The JACE has two 250V, 5 × 20 mm fuses on the printed circuit board. The main fuse is 1.5A, fast blow, Bussman GMA-1.5A. The battery fuse is a 2A, slow blow, Bussman GMD-2A. However, on-board power circuit protection is not user-serviceable. If this circuitry is suspect, contact your regional Tridium office for technical support. See the [“Returning a Defective Module”](#) section on page 27.

Standard Replacement Parts

Standard replacement parts are listed in [Table 7](#) and can be ordered from stock without restriction. Standard replacement parts cannot be returned for credit and should be disposed of in an appropriate manner.

Table 7 Standard replacement parts for the JACE-5.

Part Number	Description
10023	Battery, 12 Vdc, 1.2 AH (see “Replacing the Battery,” page 23)
10140	RS-485 connector plug, 3-position
10161	Power connector plug, 5-position
10026	LON (Lonworks) trunk connector plug, 2-position
10008	Cover, JACE-501 or JACE-511. Same cover for JACE-501-UI and JACE-511-UI.
10002	Cover, JACE-502 or JACE-512. Same cover for JACE-502-UI and JACE-512-UI.
10011	Battery/ground harness
10025	Metal backplate with labels

Field Replacement Units

To replace a faulty unit, order from the field replacement units (FRUs) listed in [Table 8](#). FRUs consist only of the JACE-5 printed circuit (PC) board with attached metal shield, as an assembly. If you require additional parts such as the metal backplate or cover, please order from the replacement parts listed above [Table 7](#).



- Notes**
- Before ordering an FRU, it is strongly recommended that you contact your normal technical support resource to eliminate the possibility of a software issue or misconfiguration problem.
 - Be sure to contact Tridium for a return authorization (RA) number before shipping the replaced assembly back for return credit or repair (see [“Returning a Defective Module,”](#) page 27). To allow proper licensing of the replacement unit, please have information ready about the existing unit, including its serial number, model number, and project licensed to, when placing the order.

Table 8 Field replaceable parts.

Part Number	Description (all are the PC board/attached metal shield, as an assembly)
R-JACE-501	FRU, JACE-501
R-JACE-501-UI	FRU, JACE-501-UI
R-JACE-502	FRU, JACE-502
R-JACE-502-UI	FRU, JACE-502-UI
R-JACE-511	FRU, JACE-511
R-JACE-511-UI	FRU, JACE-511-UI
R-JACE-512	FRU, JACE-512
R-JACE-512-UI	FRU, JACE-512-UI

To replace the FRU (PC board/shield assembly), use [Procedure 6](#) below:

**Caution**

Be sure to discharge any accumulated static by touching the metal surface of the JACE before handling board components. See the [“Static Discharge Precautions”](#) section on page 4.

Procedure 6 Replacing the shield assembly/PC board from a JACE-5 FRU.

-
- Step 1** Using the Admin Tool, back up the station database to your PC.
- Step 2** Turn off building power to the JACE-5.
- Step 3** Remove the plastic cover of the unit.
- Step 4** Unplug the power connector. Do not remove the male connector from the wiring harness.
- Step 5** Noting where each connector is located, unplug all connector plugs. Do not remove the connector plugs from their cables.
- Step 6** With a 1/4-inch nut driver, remove the four nuts holding the PC board/metal shield assembly, and set the nuts aside. Slide the module away from the studs on the metal backplate, and set it aside for shipment back to the factory.
- Step 7** Install the new unit in the proper orientation (communications connectors down) on the metal backplate. Slide the ground lug onto the upper right stud. Replace the four lock nuts and tighten.
- Step 8** Reconnect all communications connector plugs and secure in place.
- Step 9** Plug the power connector in.
- Step 10** Restore building power and verify normal operation.
- Step 11** Using the Admin Tool, install the station database from your PC.
- Step 12** Using the Admin Tool, install the new license file and start the station.
-

Returning a Defective Module

For proper credit on the returned unit, ship the defective JACE-5 to Tridium within 30 days.

Prior to returning the unit, contact one of the following Tridium offices to obtain a return authorization (RA) number and other instructions.

Please provide:

- Product model
- Serial number
- Project currently licensed to
- Nature of the defect

United States

Phone: 804-254-7086, ext. 204

Return to:

Tridium, Inc.
2248 Dabney Road, Suite F
Richmond, VA 23230
Attn: Return Department RA# _____

Europe

Phone: +44 (0) 1403 740290

Fax: +44 (0) 1403 741804

Return to:

Tridium Europe Ltd
1, The Grainstore
Brooks Green Road
Coolham
West Sussex
RH13 8GR
United Kingdom
Attn: Return Department RA# _____

Email for technical support:

supportuk@tridium.com

Email for product orders:

ordersuk@tridium.com

Asia/Pacific

Phone: +65 6887 5154

Fax: +65 6887 5342

Mobile: +65 9665 6024

Address:

Tridium Asia Pacific Pte Ltd
101 Cecil Street,
#10-11, Tong Eng Building,
Singapore 069533
Attn: Mr Lim Hoon Chiat, Engineering Manager RA# _____

Email for technical support:

hclim@tridium.com

Sales: (Australia): **Phone:** +61 7 5539 1211

Fax: +61 7 5597 2334

(Japan): **Phone:** +81 044 829 1750

Certifications

Federal Communications Commission (FCC)

This equipment generates, uses, and can radiate radio frequency energy, and if not installed and used in accordance with the instruction manual, may cause interference with radio communications. It has been tested and found to comply with the limits for a Class A computing device pursuant to Subpart J of Part 15 of FCC Rules, which are designed to provide reasonable protection against such interference when operated in a commercial environment. Operation of this equipment in a residential area may cause interference, in which case, users at their own expense will be required to take whatever measures may be required to correct the interference. Any unauthorized modification of this equipment may result in the revocation of the owner's authority to continue its operation.

Canadian Department of Communications (DOC)



Note This Class A digital apparatus meets all requirements of the Canadian Interference-Causing Equipment Regulations.



Note Cet appareil numérique de la classe A respecte toutes les exigences du Règlement sur le matériel brouilleur du Canada.

Declaration of Conformity

JACE-501, JACE-501-UI, JACE-502, JACE-502-UI JACE-511, JACE-511-UI, JACE-512, JACE-512-UI

Application of Council Directive:	89/336/EEC; 93/68/EEC
Manufacturer's Name:	Tridium, Inc.
Manufacturer's Address:	3951 Westerre Parkway, Suite 350 Richmond, Virginia 23233 United States of America
Manufacturer's Representative:	Terry Casey, President Tridium Europe Ltd 1, The Grainstore, Brooks Green Road, Coolham, West Sussex, RH13 8GR United Kingdom
Product Model Number:	JACE-501 and JACE-501-UI JACE-502 and JACE-502-UI JACE-511 and JACE-511-UI JACE-512 and JACE-512-UI
Type of Equipment:	Information Technology Equipment
EMC Standards Applied:	EN 50081-2 Emissions EN 55082-2 Immunity EN 55011 Power Line Conducted Emissions EN 55011 Power Line Radiated Emissions EN 61000-4-2 E.S.D (Electro-Static Discharge) EN 61000-4-3 Radiated Field Immunity EN 61000-4-4 E.F.T. (Electrical Fast Transient) Immunity EN 61000-4-5 Surge Immunity EN 61000-4-6 Power Line/Signal Line Conducted Immunity EN 61000-4-11 Voltage Dips/Interruptions EN 61000-3-2 Quasi-Stationary Current Harmonics EN 61000-3.3 Fluctuation & Flicker

I, **Terry Casey**, hereby declare that the equipment specified above conforms to the above Directives and Standards.

Place: Coolham, West Sussex, United Kingdom May, 2002

Position: President, Tridium Europe Ltd.

