

# JACE-403

## INSTALLATION AND CONFIGURATION INSTRUCTIONS

This document covers the mounting, installation and initial start-up of the JACE-403. It applies to the following products:

### US Model

JACE-403, JACE-403-EXT

### International model

JACE-403I, JACE-403I-EXT

These models are collectively known as the JACE-403.

This document is targeted at engineers, technicians, and service personnel who are involved in control system installation and start-up using the Niagara Framework®. These are the main topics included in this document:

- [Product Description](#), page 1
- [Included in this Package](#), page 2
- [Precautions](#), page 2
- [Installation and Start-up](#), page 3
- [Wiring Details](#), page 14
- [Figures](#), page 22
- [Related Documentation](#), page 25

Also included in this document are several appendixes, as follows:

- [Using Status LEDs](#), page 26
- [Maintaining the JACE-403](#), page 28
- [Certifications](#), page 34
- [Declaration of Conformity](#), page 35



This document does not cover station configuration. For more information about this topic, please refer to the documents listed in the “[Related Documentation](#)” section.

## Product Description

The Vykon JACE-403 (**J**ava **A**pplication **C**ontrol **E**ngine) is a compact embedded processor platform with flash memory for backup. It provides integrated control, supervision, as well as direct, on-board I/O for monitoring and control. When connected over an Ethernet network, the JACE-403 can communicate with power meters, gas meters, water meters, analog sensors, as well as legacy devices and BACnet systems using a variety of optional communications drivers. A complete set of Java-based control, application, logging, and user interface objects are included in a library for the systems integrator to create a robust monitor and control system for any size building. With the Web User Interface option (UI), the JACE-403 can directly serve live data and dynamic displays over the Internet to any standard web browser such as Netscape Navigator or Internet Explorer.

The total number of connected field devices that the standard JACE-403 can support is 27, including any combination of BACnet, LonWorks, and ModBus devices.



---

**Note** An “extended” model (JACE-403-EXT) is also available, which eliminates the total 27-device support limit in the license.

---

## Included in this Package

Included in this package you should find the following items:

- a JACE-403.
- These *JACE-403 Installation and Configuration Instructions*, Part Number 10308, Rev. 2, Revised: May 10, 2004
- a packing slip, which lists the factory settings for IP address, machine name, and host logon.
- a hardware bag containing the following items:
  - 499 ohm resistors (quantity 6).
  - 6-position I/O screw terminal connector plugs (quantity 4).
  - 3-position RS-485 screw terminal connector plug (quantity 1).
  - US models only—wire nuts (quantity 2).
  - 2-position LON screw terminal connector plug.
- Optional items (if ordered):
  - Factory installed modem.
  - RJ-45 to DB-9 adapter (for the RS-232 port).
  - Silver satin patch cable (used between the adapter and serial port).

## Precautions

This document uses the following warning and caution conventions:



### Caution

---

Cautions remind the reader to be careful. They alert readers to situations where there is a chance that the reader might perform an action that cannot be undone, might receive unexpected results, or might lose data. Cautions contain an explanation of why the action is potentially problematic.

---



### Warning

---

Warnings alert the reader to proceed with extreme care. They alert readers to situations where there is a chance that the reader might do something that can result in personal injury or equipment damage. Warnings contain an explanation of why the action is potentially dangerous.

---

## Safety Precautions

The following items are warnings of a general nature relating to the installation and start-up of the JACE-403 controller. Be sure to heed these warnings to prevent personal injury or equipment damage.



### Warning

- 
- **A 120Vac (US models) or 240Vac (International models) circuit powers the JACE-403 Installation and Configuration Instructions controller. Disconnect power before installation or servicing to prevent electrical shock or equipment damage.**
  - **Make all connections in accordance with national and local electrical codes. Use copper conductors only.**
  - **To reduce the risk of fire or electrical shock, install in a controlled environment relatively free of contaminants.**
  - **This device is only intended for use as a monitoring and control device. To prevent data loss or equipment damage, do not use it for any other purpose.**
- 

## Static Discharge Precautions

The following items are cautionary notes that will help prevent equipment damage or loss of data caused by static discharge.



### Caution

- 
- **Static charges produce voltages high enough to damage electronic components. The microprocessors and associated circuitry within a JACE-403 controller are sensitive to static discharge. Follow these precautions when installing, servicing, or operating the system:**
  - **Work in a static-free area.**
  - **Discharge any static electricity you may have accumulated. Discharge static electricity by touching a known, securely grounded object.**
  - **Do not handle the printed circuit board (PCB) without proper protection against static discharge. Use a wrist strap when handling PCBs. The wrist strap clamp must be secured to earth ground.**
- 

## Installation and Start-up

There are four major steps to installing and starting the JACE-403, as outlined below:

1. [Unpack the JACE-403](#)
2. [Install the JACE-403](#)
3. [Upgrade, License, and Configure the Host](#)
4. [Install the Station Database and Start the Station](#)

Please read through the entire document before beginning the installation procedure.

## Unpack the JACE-403

Unpack the JACE-403 and inspect the contents of the package for damaged or missing components. If damaged, notify the appropriate carrier at once and return any damaged components for immediate repair or replacement. See “[Returning a Defective Module](#)” on page 33.

## Install the JACE-403

Installing the JACE-403 has four major steps, as outlined below:

1. [Physical Installation](#)
2. [Make Connections](#)
3. [Power Up and Initial Checkout](#)
4. [Connect to the JACE-403](#)

### Physical Installation

#### Tools Required

The following tools and supplies may be required for installation:

- 7 mm (1/4-inch) nut driver: used to remove the transformer shield.
- Small flat-blade screwdriver: used for I/O and RS-485 connectors (all models) and power terminal connections (JACE-403I only).
- Phillips screwdriver: used to secure the door.

#### Mounting

Mount the JACE-403 controller in a location that allows clearance for wiring, servicing, and module removal. For mounting details refer to [Figure 9](#) on page 23 (a drill template is provided on the page after that figure).

Pay attention to the following recommendations and precautions when mounting and installing the unit.

- This product is intended for indoor use only. The unit should not be exposed to ambient conditions outside of the range of 0°C (32° F) to 50°C (122° F) and relative humidity outside the range 5% to 95% non-condensing (pollution degree 1).
- If the controller is mounted inside an enclosure, that enclosure should be designed to keep the unit within its required operating range considering a 20-watt dissipation by the controller. This is especially important if the controller is mounted inside an enclosure with other heat producing equipment.
- Minimum clearance from the wall on which the unit is mounted is 0.2-inches (provided by the dimpled mounting feet). Ensure that this space is not compromised and that airflow is not blocked behind the unit.
- Do not mount the unit:
  - in an area where excessive moisture, corrosive fumes, or explosive vapors are present.
  - where vibration or shock is likely to occur.
  - in a location subject to electrical noise. This includes the proximity of large electrical contractors, electrical machinery, welding equipment, and spark igniters.
- The unit is designed to be wall mounted with the battery situated towards the bottom of the unit. For proper airflow at temperature extremes, do not mount the unit oriented in any other way.

## Removing and Replacing the Cover

The JACE-403 cover is removable, and provides a security screw that secures the cover in place.



**Note** The security screw that ships with the JACE-403 is a standard #10-32 machine screw, pan head, 1/2-inch Phillips. You can replace this screw with a tamper-proof screw to provide a more secure installation. In addition, you can secure the unit with a padlock through the security tab that protrudes through the cover.

---

### Procedure 1 Removing the cover of a JACE-403.

---

- Step 1** Loosen the security screw and open the cover.
  - Step 2** On the inside of the door, loosen and remove the nut and locking washer that secures the green grounding strap to the cover.
  - Step 3** Pull the grounding strap off the screw post.
  - Step 4** Replace the locking washer, then the nut on the screw post and tighten.
  - Step 5** Close the door about half way.
  - Step 6** Slide the cover toward the top of the unit until the tops of the hinge tabs on the cover hit the top of the hinge slots on the left wall of the metal enclosure.
  - Step 7** Slide the hinge tabs out of the slots.
- 

### Procedure 2 Replacing the cover of a JACE-403.

---

- Step 1** Align the hinge tabs on the cover with the hinge slots on the left wall of the metal casing.
  - Step 2** Slide the hinge tabs into the slots and slide the door toward the bottom of the unit, until the bottom of the hinge tabs hit the bottom of the slots.
  - Step 3** Loosen and remove the nut and locking washer on the grounding strap post on the door.
  - Step 4** Slide the ground strap onto the screw post and replace the locking washer, then the nut and tighten.
  - Step 5** Close the door and tighten the security screw.
- 

## Make Connections

Make connections to the JACE in the following order. For specific details on each step, refer to the “[Wiring Details](#)” section on page 14.

1. With the 6-position power connector disconnected from the board, wire the power to the transformer (US models) or the power terminal block (International models).
2. Connect the Ethernet cable.
3. Connect any other communication cables.
4. Connect the I/O wiring.

See [Figure 8](#) on page 22 to locate connectors and other components on the JACE-403 controller.

## Power Up and Initial Checkout

Ensure power wiring to the transformer has been completed before proceeding (see the “[Power Wiring](#)” section on page 15). The JACE-403 controller does not include an on/off switch. To apply power, insert the 6-position power connector to the board.

Refer to [Figure 8](#) for the locations of status LEDs on the JACE-403 controller.

### Checking the Heartbeat LED

When power is first supplied to the controller, the red heartbeat LED will come on solid for approximately 10 seconds, then begin to blink. The blink pattern of the heartbeat LED under normal operation will differ for each installation (depending on station activity). But, in general, the LED should blink about once per second. The rate will be slower when the control engine is executing the station database and as more objects are added.

After applying power to the controller, if the heartbeat LED comes on (steady) and stays lit longer than two minutes, contact Systems Engineering for technical assistance. See also the “[Using Status LEDs](#)” section on page 26.

### About the Battery

The JACE-403 is provided with a sealed lead acid battery, which is nearly fully charged. Therefore, the JACE-403 has battery back up protection immediately upon installation. If battery trouble messages are generated upon power up, contact Systems Engineering for technical support.



---

**Caution** In the event of battery trouble messages, ensure the station database is backed up to removable storage such that it can be restored in the event of a power failure and loss of data.

---

For more information on the use and replacement of the battery, refer to the “[Required Battery Maintenance](#)” section on page 28.

## Connect to the JACE-403



- 
- Notes**
- These instructions assume that you have a PC installed with the Niagara Web Supervisor software, which includes the Java Desktop Environment (JDE) and the host administration tool (Admin Tool). This PC will be referred to as “your PC”.
  - You should use the same Niagara release level on your PC that you want to run in the JACE-403.
- 

Once the JACE has powered up, you should connect to the JACE with the Admin Tool to assign it a unique IP address and other network settings to be used for communications. In addition, you should check the current host date, time, and time zone, since the JACE-403 may be shipped with the battery disconnected.

Also, it is strongly recommended that you change the password for the default administrator-level host user account (tridium)—see the related [Caution](#) on [page 9](#) for more details.

The JACE-403 controller is pre-configured with an IP address in the range 192.168.1.14x, and a default subnet mask of 255.255.255.0.



- 
- Notes**
- The IP address is listed on the packing slip that accompanies the unit.
  - Make sure the PC that you use to access the JACE-403 during installation is assigned an address in the range: 192.168.1.1 to 192.168.1.254, with a subnet mask of 255.255.255.0.
- 

## Changing Networking Properties

You can use the Admin Tool from your PC to access all Niagara hosts including remote JACE-4s. In addition to station-related operations (i.e., starting and stopping stations, archiving station data, importing and exporting configuration databases, and so on), the Admin Tool allows you to change operating system parameters on the JACE-403. These changes include editing host name, TCP/IP networking properties, and setting time, date, and time zone. The reboot function allows you to restart a JACE-403 remotely to implement changes.

The right half of the Admin Tool window provides access to operating system parameters for the selected host. Six tabs are available: the Summary tab, the Network Settings tab, the Users tab, the System Time tab, DbAdmin tab, and the Installation tab.

The Networks Settings tab provides access to the selected host's networking properties, including host name (computer name) and the TCP/IP properties listed below (each property must be obtained from your Network Administrator). Use the **Apply** button to store any changes you make (note that changes are not effective until the host is rebooted). The **Reset** button restores changes since the last **Apply**.

- **Computer Name**—The name you want to use for this host.
- **DNS Domain**—The TCP/IP Domain Name System (DNS) domain this host belongs to, if used.
- **IP Address**—The unique Internet Protocol (IP) address for this host.
- **Subnet Mask**—The IP subnet mask used by this host.
- **Default Gateway**—The IP address for the device that forwards packets to other networks or subnets.
- **Hosts File**—A text file used by TCP/IP to associate host names with IP addresses.
- **DNS Servers**—The IP address for one or more DNS servers, each of which can automate associations between host names and IP addresses. The Add, Delete, Modify, and Up/Down buttons in the Admin Tool window can be used as needed to reference the DNS server IP addresses and set DNS search order.



---

**Note** If you specify a DNS server, you must provide a domain name for this host in the DNS Domain field. Otherwise, the DNS function will not work.

---

Use the following procedure to change the network settings of the new JACE-403.

### Procedure 3 Setting the IP address on a new JACE-403.

---

- Step 1** If not already installed, install the Niagara **R2.3.4** (or later) **Web Supervisor** software on your PC, including its permanent license.
- Step 2** Attach one end of a standard Category-5 Ethernet unshielded twisted pair (UTP) patch cable to the RJ-45 connector on the JACE.
- Step 3** Attach the other end of the patch cable to a network port or directly to an Ethernet hub.



**Tip** If you do not have access to a hub, use an Ethernet crossover cable to connect the JACE-403 controller directly to your PC's network port. For more details about crossover cables, see the "About Ethernet Straight Through and Crossover Cables" section in the *Niagara Networking & Connectivity Guide*.

**Step 4** Power up the JACE.

**Step 5** Assign the IP address of your PC in the range of 192.168.1.1 to 192.168.1.254. However, do not duplicate the IP address already assigned the JACE-403 or another host on the LAN.

**Step 6** From your PC, start the R2.3.4 (or later) **Admin Tool**.

- a. Click the **Start** button on the **Taskbar** and expand the **Programs** menu to view the **Niagara** folder.
- b. Click the **Admin Tool** icon to launch the **Admin Tool**.

**Step 7** In the **Admin Tool** view, click **File** on the menu, and click **Open**.  
A connection dialog is displayed.

**Step 8** Type the pre-assigned IP address of the JACE-403 and click **OK** (see the previous section "[Connect to the JACE-403](#)").

**Step 9** Log onto the JACE-403 controller with default logon user name and password, as it appears on the packing list. Typical defaults are: user name = **tridium** and password = **niagara**. Click **OK**.  
The JACE-403 controller (IP address) appears in the Admin Tool view as an open host.



**Note** By default, the **Summary** tab is shown first. Among the items listed is an **AC Power Status**, which shows "ok" if the power is good. If the JACE loses power (and is running on its battery), this status shows "failed." See also "[Configure Power Shutdown Options](#)," page 11.

**Step 10** Click the **Network Settings** tab.

**Step 11** Assign the JACE-403 a unique IP address and other network settings to be used for communications, as described above.



**Note** Once you have made changes to one or more network settings, you must reboot the host for those changes to be implemented.

**Step 12** From the menu, select **Admin Tool > Host > Reboot** to implement your changes.

The JACE is now accessible using the IP address you assigned it (and not the default IP address).



**Note** An **ipchanges.txt** file is created or updated in the <x>:\niagara\<release>\nre\user directory on your PC whenever you change the IP address of a host using the Admin Tool. If needed, you can refer to this file to see the new (and previous) IP address. Ensure that you do not change the IP to an illegal IP address such as xx.xx.xx.255, xx.xx.xx.0, or 224.xx.xx.xx or higher.

## Setting Host Date and Time

Use the **System Time** tab of the Admin Tool to access the host's system time, date, and time zone. To change the settings, click on the information you want to change and type the new information. When finished, click **Apply**. Changes you make in these settings become immediately effective on the host.

## Configuring Host Users

Use the **Users** tab of the Admin Tool to access host user accounts on the JACE-403. The top area shows current user accounts, which you select by clicking on the user name. A selected user can be deleted, or have password and/or groups assignments modified (available user groups are accessed in the lower area).



### Caution

It is strongly recommended that you change the password for the default, administrator-level, *host* user account (tridium) upon installation. This account cannot be deleted. Signing on as the “tridium” administrator allows you to modify *all* host user accounts.



### Note

Be aware that after you modify this administrator user and you then lose or forget the new password, you must contact Systems Engineering for a procedure to regain administrative host access.

You can also add a new user. This produces a New User dialog to establish the User Name and Password. By default, a new user is not assigned to any user group(s); you need to check the Administrator group assignments in order for the user to use the JDE Admin Tool.

Use the **Apply** button to store any modifications, which become effective immediately. The **Reset** button restores changes since the last Apply.

# Upgrade, License, and Configure the Host

This step consists of three main tasks:

1. [Install the Software](#)
2. [Configure Power Shutdown Options](#)
3. [Configure the Serial Ports](#)

## Install the Software

Each JACE-403 controller is shipped with the Wind River VxWorks operating system and the appropriate JVM (Java™ virtual machine) installed. However, the Niagara Runtime Environment (NRE) software, and the Niagara service (NIAGARAD) are not installed and you must install them.

Use the following procedures to install the software. Consult the *Niagara Release 2.3.5 Installation and Upgrade Instructions* for more information.

**Caution**

This upgrade also automatically performs a firmware upgrade to the I/O processor's flash memory, if required. Do not remove power from the unit during the I/O upgrade or damage will occur, which would require replacement of the JACE-403.

These procedures assume that you have successfully tested connectivity to the JACE-403 and can access the unit over the Ethernet LAN.

**Procedure 4 Installing the software.**

**Step 1** Using Windows Explorer, copy the **emb** and **nt** directories from the R2.3.4 (or later) installation CD to the following directory on the hard drive of your PC:

`<x>:\niagara\<release>\`

where `<x>`: is the drive where you installed Niagara, and `<release>` is the Niagara release you installed in [Step 1](#) of [Procedure 3](#).

**Step 2** Using the R2.3.4 (or later) **Admin Tool**, connect to the JACE-403 as described in [Procedure 3](#).

**Step 3** Click the **Installation** tab.

**Step 4** On the **Installation** view, click the **Installation Wizard** button.

**Step 5** In the **Select Distribution Directory** dialog, select **emb** and click the **Install** button.

**Step 6** In the **Niagara Remote Installation** dialog, click the radio button next to **Upgrade**, then click **Next**.

**Step 7** In the **Upgrade** dialog box, click the check boxes for **Upgrade OS** and **Upgrade NRE**, then click **Next**.



**Note** You must upgrade `niagarad` when you upgrade the OS.

**Step 8** In the **Configure Modules** dialog box, click inside the **Upgrade/Add** column for each module licensed for installation on the JACE-403.

A red check mark appears for each selected module.



- Notes**
- Be sure to choose the **ndio** module. The on-board I/O requires the **ndio** module to function.
  - Remember that the total number of connected field devices that a JACE-403 can support is 27, including BACnet, LonWorks, and ModBus devices.
  - The JACE-403 has finite memory resources (software modules run out of flash memory rather than a hard disk). Therefore, select only those modules that are required for station operation. If you are unsure about the software modules that have been purchased and licensed for the JACE-403, check the license by clicking **View License** on the **Installation** tab of the **Admin Tool** view.

**Step 9** Click **Next** to continue.

**Step 10** On the **Database Backup** dialog box, click the red check mark next to the database name and click **Next** to continue. You do not need to back up the pre-installed “test” database on the JACE-403. The **Niagara License** dialog box opens.



**Note** The JACE-403 controller is shipped with the licence file already installed.

**Step 11** On the **Niagara License** dialog box, click **Finish**.

A text box displays the tasks selected for the software upgrade.

**Step 12** Click **OK** to continue.

A dialog displays each task as it is performed. Depending on the number of tasks to be performed, the process may take from one to three minutes.

**Step 13** When complete, click **OK**.

## Configure Power Shutdown Options

If desired, you can change the operation of JACE-403's "power monitoring/shutdown" mechanism by editing the **drivers.properties** file. Any changes to this file requires a station restart (host reboot) to become effective.

**Table 1** lists power parameters for the JACE-403 found in **drivers.properties**. For additional information, please refer to the Engineering Notes document *Niagara System and Power Monitoring*.

**Table 1** JACE-403 power shutdown parameters in the **drivers.properties** file.

Parameter, Default Value	Description
<code>power.enabled=true</code>	<p>Enables the power driver, which provides graceful shutdown of the JACE on AC power loss. When set to true, the next two parameters apply. When set to false:</p> <ul style="list-style-type: none"> <li>the JACE does not monitor the A/C power</li> <li>on power loss, the JACE runs on battery until it is drained (unless AC power is restored).</li> </ul> <p><b>Note:</b> You should leave this value set to true, the default.</p>
<code>power.pollRate=15</code>	<p>The rate (in seconds) that the power monitor of the JACE waits before checking for A/C power loss. The monitor wakes up every <code>pollRate</code> seconds, checks the A/C power status, then goes back to sleep (if the power status is OK). However, if the JACE has lost A/C power, the monitor generates a <i>station</i> alarm and starts the shutdown timer. Default is 15 seconds. Station alarms are sent to the Station object's notificationClass.</p>
<code>power.shutdownDelay=60</code>	<p>Number of seconds the JACE waits between detecting the loss of A/C power and performing a graceful shutdown (where the JACE does a database backup and turns the board off). Typically, the default value is recommended. You can increase this time, however, this means more time running on battery power. In this case, if multiple lengthy power failures occur in succession, the battery may become completely discharged. Default is 60 seconds. If a station is <i>not</i> running, the JACE runs from the battery for 5 minutes before shutdown.</p>
<code>power.batteryTestRate=15</code>	<p>Number of minutes between the periodic testing of the backup battery under a simulated load. Default (and <b>minimum</b> recommended) value is 15 minutes.</p> <p>When the test runs, a 900mA load is placed on the battery for less than one second. If the voltage drops below a predefined value, then the "battery test failed". If the voltage is higher, then the "battery test passed".</p> <p>A station alarm is generated <i>only</i> when the new outcome is different than the previous test. If a battery is marginal, the test may go from "failed" to "passed", and then "failed" again.</p>

Use the following procedure to view or edit the **drivers.properties** file.

**Procedure 5 Viewing or editing the drivers.properties file.**

- 
- Step 1** Using the R2.3.4 or later **Admin Tool**, connect to the JACE-403 as described in [Procedure 3](#).
- Step 2** Click the **Installation** tab.
- Step 3** Click **Edit drivers.properties**.  
The drivers.properties file opens in a text editor.
- Step 4** Make any changes to the text of the file.
- Step 5** From the file menu, choose **File > Close**.  
If you made any changes, you are prompted to save them, otherwise the window closes.
- Step 6** If prompted to save your changes, click one of the following:
- **Yes** to save your changes. The file saves and the window closes.
  - **No** to discard your changes. The window closes.
  - **Cancel** to return to the editing window, then refer to [Step 4](#).
- Step 7** From the menu, select **Admin Tool > Host > Reboot** to implement your changes.
- 

## Configure the Serial Ports

The JACE-403 has two serial ports (one RS-232 and one RS-485) and one optional on-board 56k modem. However, only *two* of these three serial channels can be active at any one time.

By default, COM1 is assigned to the RS232 port and COM2 is assigned to the RS485 port. Changes to these assignments can be made using the R2.3.4 or later Admin Tool.

You can choose from one of the following options for configuring your serial ports:

**Table 2 Serial port configuration options.**

<b>Option 1 (default)</b>	COM1=232 COM2=485
<b>Option 2</b>	COM1=232 COM2=MODEM
<b>Option 3</b>	COM1=485 COM2=MODEM

Use the following steps to configure the serial ports.

**Procedure 6 Configuring serial ports.**

- 
- Step 1** As described in [Procedure 3](#), open the R2.3.4 (or later) **Admin Tool** and connect to the JACE-403.
- Step 2** Click the **Network Settings** tab.
- Step 3** On the **Network Settings** tab, click **Edit Port Properties**.  
The port.properties file opens in a text editor (see [Figure 1](#)).

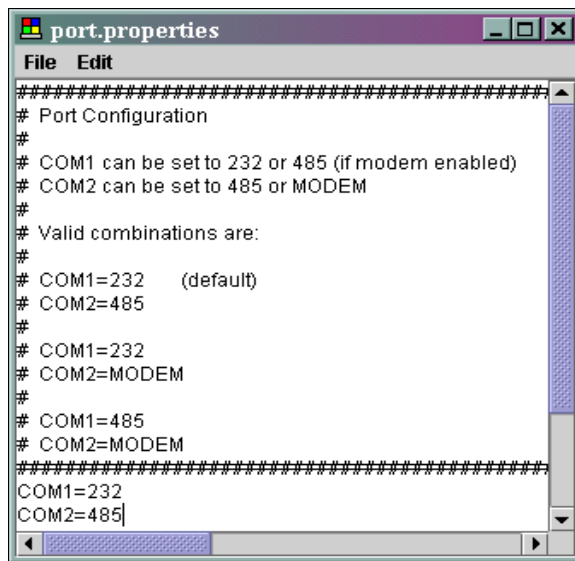
**Figure 1** port.properties file opened for editing.

- Step 4** Make any changes to the text of the file, using any of the options from [Table 2](#).
- Step 5** From the file menu, choose **File > Close**.  
If you made any changes, you are prompted to save them, otherwise the window closes.
- Step 6** If prompted to save your changes, click one of the following:
- **Yes** to save your changes. The file saves and the window closes.
  - **No** to discard your changes. The window closes.
  - **Cancel** to return to the editing window, then refer to [Step 4](#).
- Step 7** From the menu, select **Admin Tool > Host > Reboot** to implement your changes.
-

## Install the Station Database and Start the Station

This step assumes that you have created a station database on your PC and need to install that database onto the JACE-403. Use the following procedure to install a previously created station on the new JACE-403.



**Note** Installing a station from your PC places everything in your local station database folder (<x>:\niagara\<release>\stations\<stationname>) onto the JACE-403. Since the JACE-403 has limited memory resources, you should limit what is in your local station database folder so you do not exhaust the resources on the JACE.

### Procedure 7 Installing and starting a station.

- 
- Step 1** As described in [Procedure 3](#), open the **Admin Tool** and connect to the JACE-403.
- Step 2** Click the **Installation** tab.
- Step 3** On the **Installation** tab, click the **Install Station** button.
- Step 4** From the list of available stations on your PC, choose the desired station and click **OK**.
- Step 5** Verify your intent to overwrite the existing database by clicking **Yes**.
- Step 6** If more than one version or format of the station database exists on your PC, select the one that you intend to install and click **OK**.
- A progress dialog displays tasks as it completes them. These messages indicate when the installation wizard is converting the database, starting maintenance, and reconnecting to the station.
- Step 7** When the installation wizard indicates that it is complete, click **OK**.
- The installation wizard automatically starts the station. Therefore, you should not have to perform this step separately. However, if the status of the station shows “idle”, use the next step to start the station on the JACE controller.
- Step 8** From the **Admin Tool** view, click the station name and click the **Start** button  on the toolbar. Verify that after showing a status of “starting,” the selected station’s status updates to **running**.
- 

## Wiring Details

The following sections provides details on:

- [Power Wiring](#)
- [Communications Wiring](#) including:
  - [Ethernet](#)
  - [Serial](#)
  - [LonWorks \(LON\)](#)
  - [Modem \(Optional\)](#)
- [I/O Wiring](#)

## Power Wiring

Building power is wired directly to the transformer supplied with the JACE-403. There is no disconnect switch in the unit, therefore you should wire the JACE to an external switch or breaker. Some local codes require the switch to be in sight of the unit. The switch must be capable of 120Vac (or if a JACE-403I, 240Vac), plus sufficient capacity for test equipment.

### About the Transformer

The JACE-403 ships with a 120Vac, 50/60 Hz transformer and 12V battery. The JACE-403I ships with a 240Vac, 50/60 Hz transformer and 12V battery.

The transformer provides power to the controller in a 14-CT-14 configuration (28Vac center tapped). The power connector has been disconnected for shipping.

The following things should be noted about the JACE-403 transformer:



#### Warning

- **Wiring is to be made to the supplied transformer. All connections should be made in accordance with national and local electrical codes. Use copper conductors only.**
- **Do not power other devices from the transformer of the JACE. The transformer should be dedicated to running the JACE.**
- **Do not attempt to use any other power source or otherwise defeat the isolation provided by the integral transformer. A two-wire power source, including a 24V transformer, can cause permanent damage or greatly shorten the life of the unit.**
- **Verify that neither side of the transformer's secondary winding is connected to earth ground or building neutral.**

### Making the Power Connection to the Transformer

With the 6-position power connector disconnected from the PCB, unscrew the nut and locking washer and remove the metal enclosure of the transformer.



#### Note

As typically required by code, high voltage “Class 1” wiring must be confined behind the transformer’s enclosure divider. Be sure to replace this barrier after completing the wiring. Do not pinch wires underneath the barrier when re-installing the barrier.

**For JACE-403**—Using the provided wire nuts, connect 120Vac 60 Hz power to the transformer and power connector using the information in [Table 3](#).

**Table 3** US models—building power termination.

Building Power Source		
Type of Wire	Typical Color of Wire	Termination point
Ungrounded—Hot	Black	Either wire of the 120V transformer
Grounded—Neutral	White	Other wire of the 120V transformer
Grounding—Ground (Earth)	Green or bare copper	Grounding stud

**For JACE-403I**—Connect 240Vac 60 Hz power to the power terminal block using the information in [Table 4](#).

**Table 4 International models—building power termination.**

Building Power Source		Termination point
Type of Wire	Typical Color of Wire	
Ungrounded—Hot	Brown	Either empty terminus of the terminal block
Grounded—Neutral	Blue	Other empty terminus of the terminal block
Grounding—Protective Earth (Ground)	Green/yellow or bare copper	Grounding stud

## Communications Wiring

All communications wiring is made through knockouts adjacent to the communication ports. Prior to connecting cables, ensure that the grommet bushing has been installed for each knockout. Employ strain relief on the communication wiring to prevent damage to the controller.

### Ethernet

A single, female 10/100-Mbit Ethernet connection is provided on the controller. This connection is capable of running at either 10 Mbps or 100 Mbps—it automatically adjusts to either speed. This means the JACE-403 can exist on the same network with a mixture of 10BaseT and 100BaseTX hardware connected to a smart 10/100 hub capable of adjusting to the devices it supports.

Connection is made via a standard male RJ-45 (8-wire) connector. Using a Category 5 unshielded twisted pair (UTP) cable, connect one end of the cable through the knockout adjacent to the RJ-45 connector on the JACE, and the other end to a hub on the Ethernet LAN.

The maximum end-to-end distance from the controller to the hub is 328 feet (100m).

### Serial

There are two serial ports on the JACE-403. From the top of the board (see [Figure 8](#)), the top serial port is an [RS-232](#) port using an RJ-45 connector. Below this is a two-wire with shield, non-isolated [RS-485](#) port.

#### RS-485

RS-485 multi-point connections are made to the 3-position, screw terminal connector on the board. Wire to this connector with shielded 18-22AWG wiring (refer to the TIA/EIA-485 standard). The screw terminals (from top to bottom) are shield, plus (+), and minus (–).

#### RS-232

An RS-232 serial port connection can be made to the female (socket) RJ-45 connector using an 8-conductor flat silver satin stranded cable with standard male (plug) RJ-45 connectors. Connect the flat satin cable (maximum distance 50 feet) through the enclosure knockout nearest the port. This “straight-through” cable is then connected to a socket-to-socket type RJ-45-to-DB-9 adapter.

The JACE-403 is a serial DTE device, such another DTE device (PC, for example) requires a “null modem” adapter (part number 10148, optional item). If connecting the JACE-403 to a DCE device (modem, for example), a straight-through adapter is used. [Table 5](#) provides pinouts for both types of RJ-45 to DB-9 adapters.



- Notes**
- Silver satin cable is not standard Ethernet UTP cable, in which the pairs are twisted around each other. The twisting of the pairs may cause undesirable effects on the serial communication, therefore we recommend the use of flat silver satin cable instead.
  - Flat silver satin cable is unshielded. If installing this cable in a noisy electrical environment, run the cable through conduit.

Table 5 RJ-45 to DB-9 adapter pinouts.

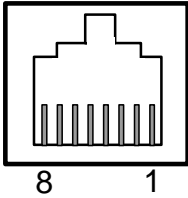
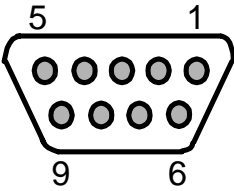
RJ-45 and DB-9 Pinout References	Type of Adapter	RJ-45 Socket Pin	Signal		DB-9 Socket Pin
<b>RJ-45 Socket (female)</b> 	<b>Null Modem</b> (for connecting to another DTE device) <b>Part number 10148</b>	5	DCD	Data carrier detect	1
		3	TXD	Transmit data	2
		6	RXD	Receive data	3
		8	DSR	Data set ready	4
		4	GND	Ground	5
		1	DTR	Data terminal ready	6
		7	CTS	Clear to send	7
		2	RTS	Request to send	8
		—	not used on the JACE-4		9
<b>DB-9 Socket (female)</b> 	<b>Straight-through</b> (for connecting to a DCE device)	5	DCD	Data carrier detect	1
		6	RXD	Receive data	2
		3	TXD	Transmit data	3
		1	DTR	Data terminal ready	4
		4	GND	Ground	5
		8	DSR	Data set ready	6
		2	RTS	Request to send	7
		7	CTS	Clear to send	8
		—	not used on the JACE-4		9

## LonWorks (LON)

A single, two-pin, male LonWorks FTT-10A Weidmuller connection is provided on the controller. This connection supports twisted pair, unshielded, polarity-insensitive, peer-to-peer communications at 78 Kbps.

Refer to the *LonWorks FTT-10A Free Topology Transceiver User's Guide* (078-0156-01F) for technical guidelines associated with free topology restrictions and the *Junction Box and Wiring Guidelines for Twisted Pair LonWorks Networks* (005-0023-01) for more detailed information on wiring specifications. These documents are available on Echelon's web site ([www.echelon.com](http://www.echelon.com)).

## Modem (Optional)

The female RJ-11 connection for the modem is located below the RS-485 port. Connect one end of a standard flat satin telephone cable (4-connector) through the adjacent knockout to the modem's RJ-11 connector and the other end to an analog telephone port.

This modem is approved for US use only, and must be tested for use in other countries.

## I/O Wiring

The JACE-403 provides six (6) universal **inputs** supporting analog inputs (temperature, resistance, voltage, and current) and digital inputs (contact closure, pulse count), as well as four (4) form-C (SPDT) relay **outputs**.

Each type of input or output used requires a special Niagara Direct Input/Output (Ndio) object to be added to and configured in the station database. These objects act as the station interface to the physical I/O points. The Ndio objects you need for each input or output type are noted ahead in **boldface**.

For configuration details on Ndio objects, see Chapter 10 of the *Niagara Standard Programming Reference, r2.3.5*.

### Inputs

Each of the 6 universal inputs can support any one of the following:

- Type 3 (10K) **Thermistor**
- **Resistive**
- **0–10 Vdc**
- **4–20 mA**
- **Binary Input**

#### Thermistor

The inputs support Type 3 10K Thermistor temperature sensors with a sensor range of  $-10^{\circ}$  to  $135^{\circ}\text{F}$  ( $23.3^{\circ}$  to  $57.2^{\circ}\text{C}$ ), using an **NdioThermistorType3Input** object. Input accuracy is in the range of  $\pm 1\%$  of span.

Figure 2 shows the wiring diagram.

Figure 2 Thermistor wiring.

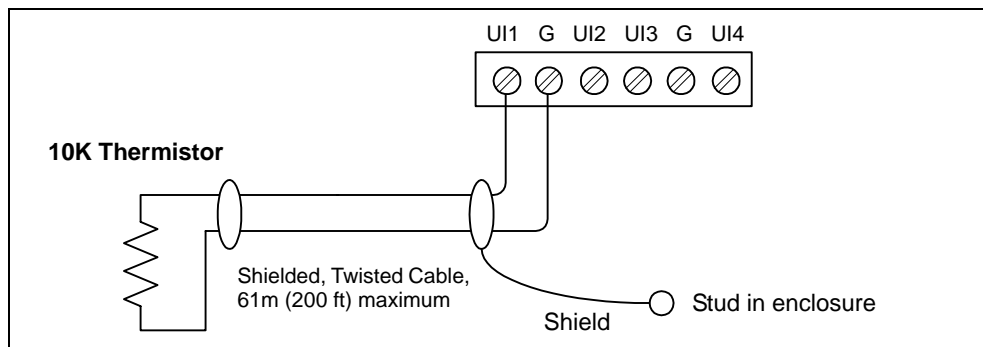

**Note** Other types of 10K thermistor sensors can be supported by using an **NdioResistiveInput** object and entering the appropriate values in object's 20 data-point linearization table. An example for a 10K3A1 type thermistor sensor is shown in the r2.3.5 *Niagara Standard Programming Reference* Chapter 10 (Ndio Objects) section about the "NdioResistiveInput" object.

Also, note that UI inputs are optimized to provide the best resolution around the 10K ohm range. For a sensor with a range far from 10K ohms (such as a 100-ohm or 1000-ohm type), resolution will be poor. To use such a sensor, it is recommended you install a transmitter that produces a Vdc or mA signal, and then wire the transmitter to the UI according to the **Resistive** or **4–20 mA** instructions.

## Resistive

The inputs support resistance inputs with a range of 0–100K ohms. Input accuracy is in the range of  $\pm 1\%$  of span. This type of load requires the **NdioResistiveInput** object.

**Figure 3** Resistive wiring.

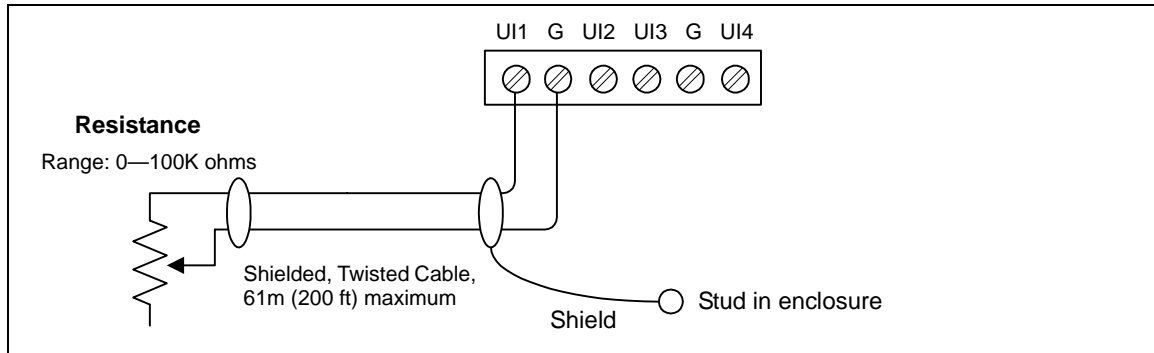

## 0–10 Vdc

The inputs support self-powered 0–10 Vdc sensors. Input impedance must be greater than 5K ohms. 0–10 volt accuracy is  $\pm 2\%$  of span, without user calibration. [Figure 4](#) shows the wiring diagram.

0–10 Vdc sensors require the **Ndio0to10VInput** object.

**Figure 4** 0–10 Vdc wiring.

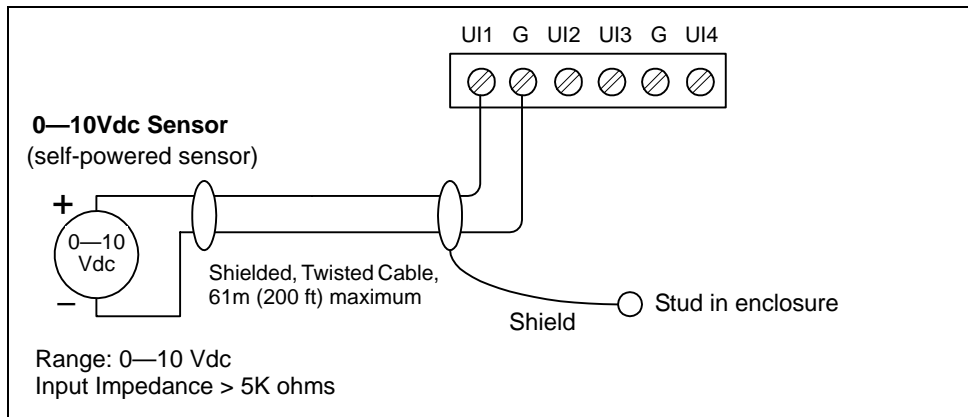

## 4–20 mA

The inputs support self-powered or controller-powered 4–20 mA sensors. For controller-powered sensors, the controller's two V+ terminals supply 20 Vdc, at up to 80 mA combined. Input accuracy is  $\pm 2\%$  of span, without user calibration. The input requires an external 499-ohm resistor for current input (six are supplied with the unit).

4–20 mA sensors require the **Ndio0to10VInput** object.

[Figure 5](#) shows wiring used for a self-powered sensor (top) and a 2-wire controller-powered sensor (bottom).

Figure 5 4 to 20 mA wiring.

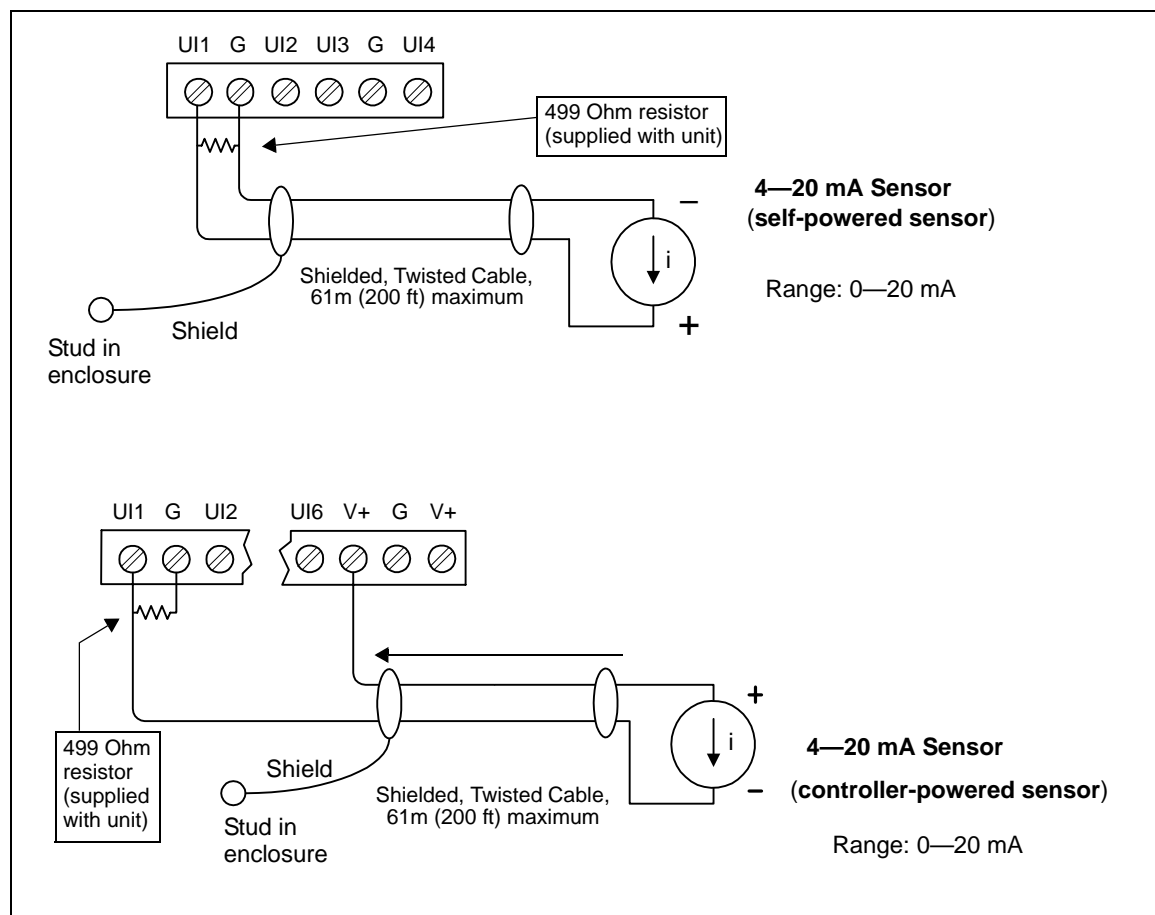

## Binary Input

The inputs support both pulse contacts and normal dry (equipment status) contacts.

- Pulse contacts may have a change-of-state (COS) frequency of up to 20 Hz with a 50% duty cycle.  
*Note:* Minimum dwell time must be > 25ms.
- Standard dry contacts must have a 1 Hz. (or less) COS frequency, with minimum dwell time > 500ms.

Both types of dry contacts support 3.3 Vdc open circuits or 330  $\mu$ A short-circuit current.

Figure 6 shows the wiring diagram.

For a pulse contact, use the **NdioHighSpeedCounterInput** object in the station database.

For other dry contacts, use the **NdioBinaryInput** object.

Figure 6 Binary input wiring.

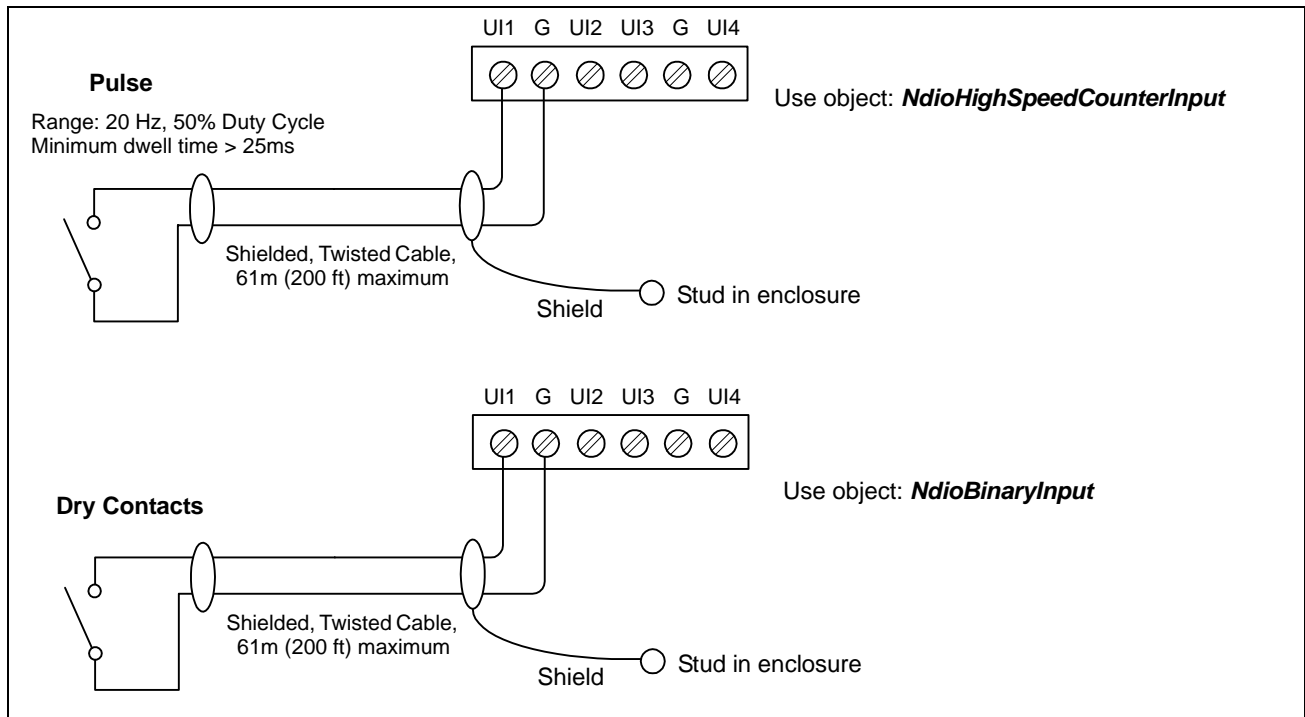

## Outputs

Four (4) form-C relay outputs provide isolated dry-contact control of 24 VAC/DC loads at up to 2A resistive. An LED indicator for each relay is located between the relay and the wiring connection point (see the “[Relay Output Status](#)” section on page 27). For each output, use an **NdioBinaryOutput** object in the station database.

Figure 7 shows example wiring diagrams.

Figure 7 Example DO (relay) output wiring.

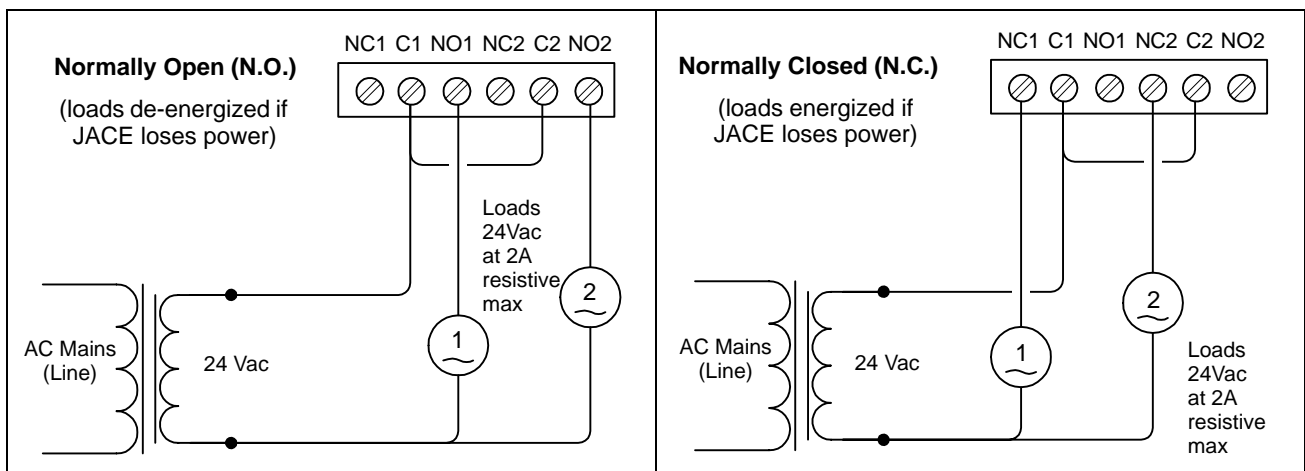

# Figures

The following figures provide a [board layout](#), [mounting details](#), and a [mounting guide](#).

## Board Layout

Figure 8 JACE-403 board layout details.

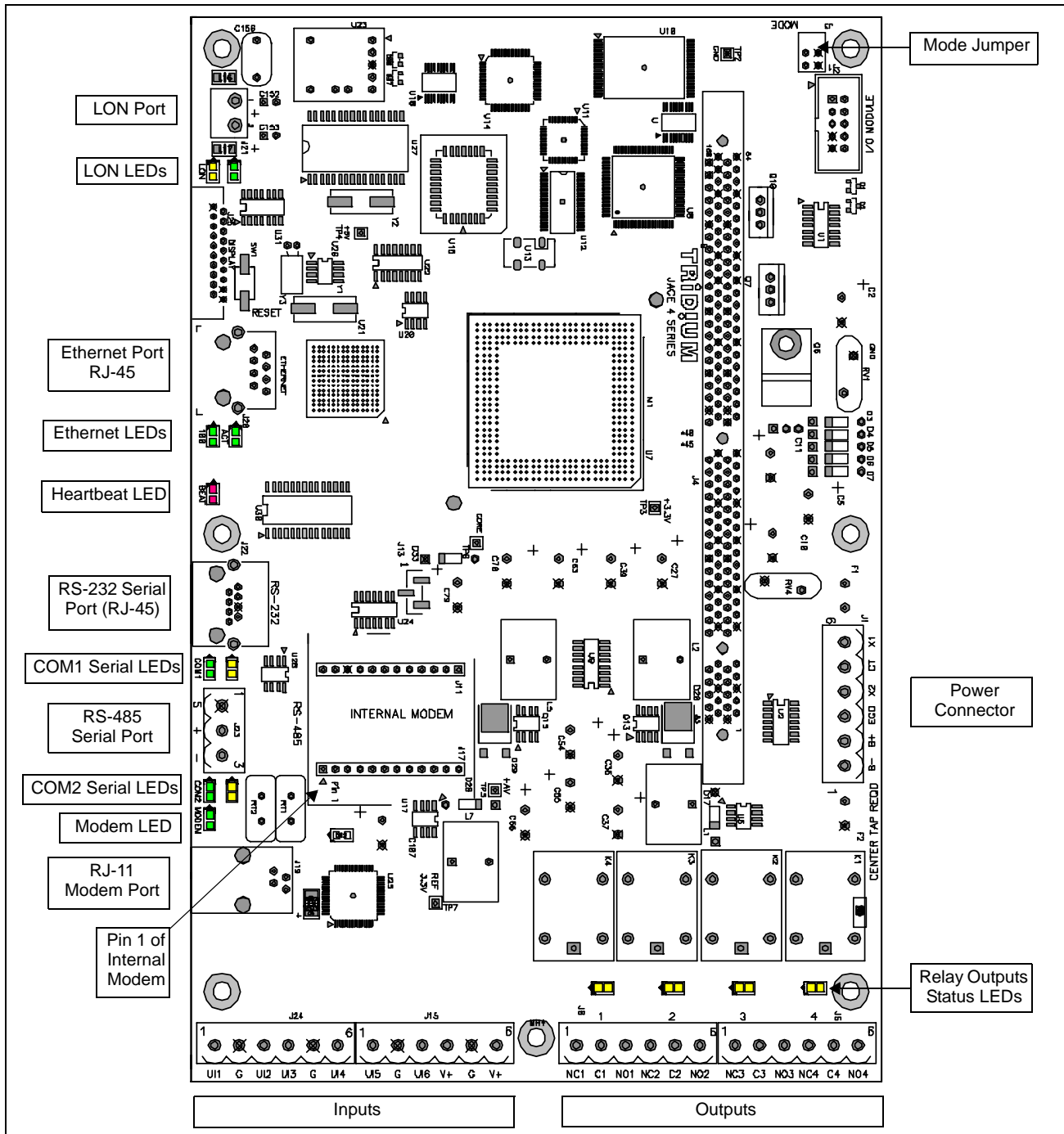

# Mounting Details

Figure 9 Mounting details.

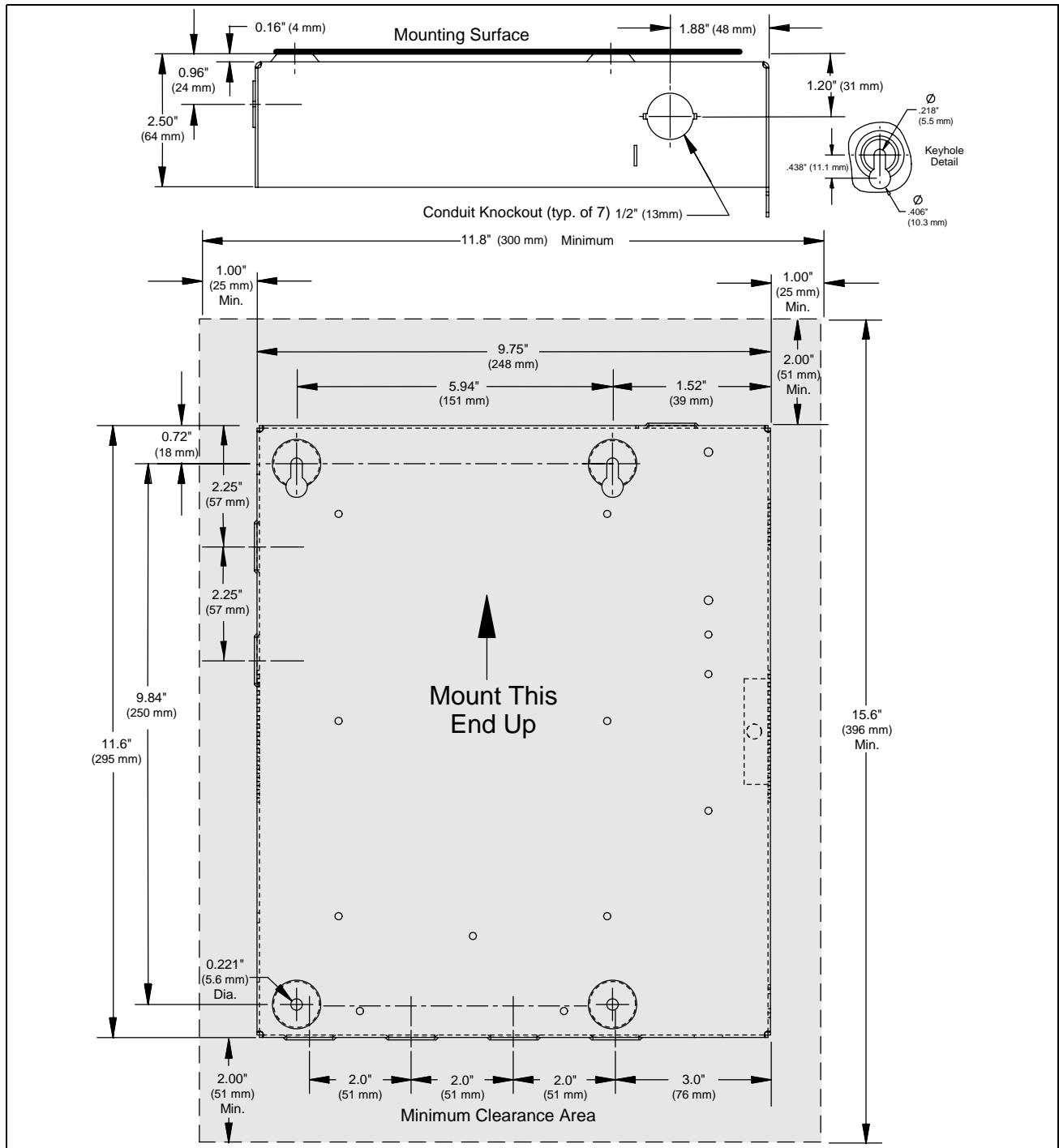

## Mounting Guide

The figure on the next page provides a mounting guide for the JACE-403.

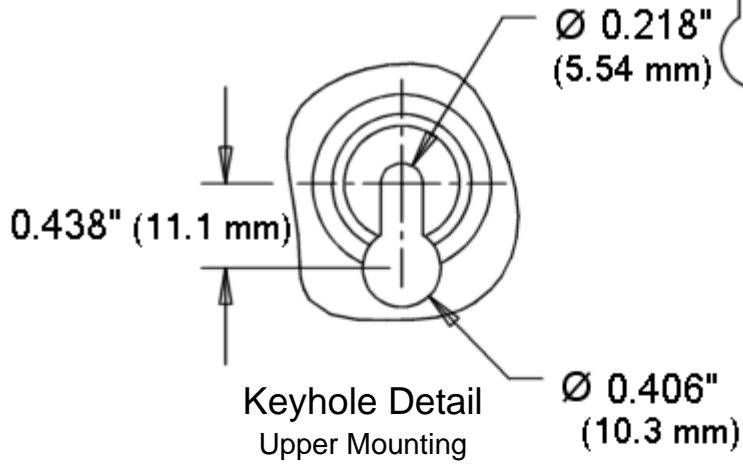

### JACE-403 Mounting Guide

9.84" or  $9\frac{27}{32}$ "  
(250 mm)



Mount with this end up.

**Note:** Electronic and printed versions of this guide may not show the mounting guide to scale. Verify all measurements before drilling.

Lower mounting holes are 0.221" (5.61 mm) dia.

5.94" or  $5\frac{15}{16}$ "  
(151 mm)



## Related Documentation

For more information on configuring and using the JACE-403 controller, consult the following documents available from the secure section of [www.tridium.com](http://www.tridium.com):

- *Niagara Release 2.3.5 Installation and Upgrade Instructions*
- *Niagara System and Power Monitoring, Engineering Notes*
- *Niagara Networking & Connectivity Guide*
- *Niagara Standard Programming Reference, Release 2.3.5*

# Using Status LEDs

---

The JACE-403 controller includes a series of LEDs that can be used to determine the status of a variety of normal operating parameters for the unit. They are located on the circuit board. From the top of the board to the bottom, these include the following:

- [LON \(LonWorks\) Port](#)
- [Ethernet Port](#)
- [Heartbeat](#)
- [Serial Ports](#)
- [Modem](#)
- [Relay Output Status](#)

Refer to [Figure 8](#) on page 22 for the exact locations of status LEDs on the JACE-403 controller.

## LON (LonWorks) Port

Two LEDs are located below the LON port and show transmit and receive activity.

- The **yellow** transmit LED (TxD) indicates that the JACE is *transmitting* a message on the LON trunk.
- The **green** receive LED (RxD) indicates that *another* LonWorks device is transmitting a message.

## Ethernet Port

The Ethernet port has two green LEDs, located below the Ethernet connector.

- The LED marked “100” indicates whether the JACE-403 is operating at 10 Mbps (Ethernet) or 100 Mbps (Fast Ethernet). If the 100 LED is on, the network connection is operating at 100 Mbps. Otherwise, the port is communicating at 10 Mbps.
- The “ACT” LED indicates activity on the port as follows:
  - **Off**—No Ethernet link is made
  - **On**—Ethernet link is present, but no activity on the LAN
  - **Blinking**—Ethernet link is present with data activity on the LAN.

## Heartbeat

The “BEAT” LED is located below the Ethernet status LEDs, and is red. Under normal operation, this LED should blink about once per second. The blink pattern will differ as station activity increases, but any pulse rate from once per second to 10 blinks per minute usually indicates normal control engine activity. If the heartbeat LED stays on constantly or does not light, contact System Engineering for technical support.

## Serial Ports

The status LEDs for the serial ports are located below the respective RS-232 and RS-485 ports. They are marked COM1 and COM2 and correspond to the software configuration of the COM ports (see the “[Configure the Serial Ports](#)” section on page 12). They show the transmit and receive information for the serial ports and optional modem.

- The **yellow** transmit LED indicates that the JACE-403 is *sending* data out the serial port over a communications line to a connected device.
- The **green** receive LED indicates that the JACE-403 is *receiving* data from a connected device.

These LEDs are driven by pulse detectors that provide a fixed on-time when data is detected on the port. If these LEDs are on constantly, this indicates a problem with the communications channel, such as a shorted wire or reversed wiring.

## Modem

The modem LED is located directly above the RJ-11 connector for the modem, and is green. When lit, it indicates that the modem is connected to another modem (a carrier is detected). In this case, the serial port LEDs for COM2 should indicate transmit and receive activity—see “[Serial Ports](#)” above.

## Relay Output Status

There are four (4) relay output status LEDs. These are yellow LEDs, with each one located below the associated form-C relay (just above the screw terminals for each output’s wiring).

Under normal operation, a relay status LED indicates activity as follows:

- **Off**—Relay coil is not energized
- **On**—Relay coil is energized

Therefore, for a circuit with a normally open contact, an On status indicates that the contact is closed. For a circuit with a normally closed contact, an On status indicates that the contact is open.

# Maintaining the JACE-403

---

This section provides information on the following topics:

- [Cleaning](#)
- [Required Battery Maintenance](#)
- [Replacement Parts](#)
- [Returning a Defective Module](#)

## Cleaning

If dust or metal filings are present inside the unit, clean with vacuum or compressed air. Otherwise, no cleaning inside the unit is required. Optionally, if the outside of the metal enclosure becomes dirty, you can wipe it with a damp cloth and mild detergent.

## Required Battery Maintenance

Battery life expectancy is a function of its discharge cycles (the number of discharges and their depth) and the ambient temperature of the battery during normal operation. In most applications, the battery should see relatively few discharges. Therefore, ambient temperature has more to do with determining the life expectancy of the battery than does any other factor. If the JACE-403 is installed in a conditioned space, the battery should provide dependable service for approximately three years (average). In an environment where the operating temperature is higher (that is, 50°C or 122°F), you should only expect the battery to last approximately one year.

The sealed lead acid battery in the JACE-403 controller is nearly fully charged before shipping. The battery is automatically float-charged during normal operation (while power is applied to the unit). The JACE-403 monitors the battery and periodically loads the battery to test its ability to maintain battery-backed functions. You should investigate any battery trouble message. Check the voltage level and its connections to the unit. Replace the battery as required.

To order a new battery, see the “[Standard Replacement Parts](#)” section on page 30.

## Replacing the Battery



### Warning

---

**When replacing the battery or harness, maintain proper polarity as marked on the label inside the unit. Although the JACE-403 is fully protected against shorted battery terminals, the battery itself is not internally protected. Use extreme care to not short circuit the battery. A shorted battery may overheat rapidly and damage the power wiring harness or cause other physical harm to the hardware.**

---

To replace the battery, proceed as follows:

**Procedure 8 Replacing a JACE-403 battery.**

- 
- Step 1** Unplug the 6-position power connector. Do not remove the male connector from the wiring harness.
- Step 2** Using a 7 mm (1/4-inch) nut driver, unscrew the lock nut from the bracket that is holding the battery.
- Step 3** Hold the battery in place while you remove the bracket that secures it to the bottom of the unit.
- Step 4** Disconnect the two quick connect terminals on the battery.
-  **Note** The JACE-403 will lose its time and date settings if it is disconnected from both battery and AC power for more than one hour.
- 
- Step 5** Remove the old battery and recycle as defined by your regional codes. For recycling within the US, see the labelling on the battery.
- Step 6** Connect the quick connect terminals to the new battery. Make sure the RED (+) wire is connected to the positive terminal of the battery and the BLACK (-) wire is connected to the negative terminal.
- Step 7** Secure the new battery to the bottom of the unit with the bracket and tighten the lock nut.
- Step 8** Plug the power connector in and verify normal operation.
- 

## Replacement Parts

Servicing the JACE-403 may call for replacement parts. There are three categories of parts:

- [Non-replaceable Parts](#)
- [Standard Replacement Parts](#)
- [Field Replacement Units](#)

## Non-replaceable Parts

Other than the parts listed in the replacement parts sections, there are no serviceable components on the base assembly.

## Memory

Any addition, modification, or replacement of memory components requires software configuration and is not a field upgrade. For additional information on modifying the memory capacity of the JACE-403, consult your regional Tridium office.

## Fuses

The JACE has two 250V, 2.5A delay (series 372) fuses on the printed circuit board. These fuses are Wickman F015-2.5A250V fuses. However, on-board power circuit protection is not user-serviceable. If this circuitry is suspect, contact your regional Tridium office for technical support. See the [“Returning a Defective Module”](#) section on page 33.

## Standard Replacement Parts

Standard replacement parts are listed in [Table 6](#) and can be ordered from stock without restriction. Standard replacement parts cannot be returned for credit and should be disposed of in an appropriate manner.

**Table 6** Standard replacement parts.

Part Number	Description
10023	Battery, 12 Vdc, 1.2 AH (see <a href="#">“Replacing the Battery,”</a> page 28.)
10026	LON (LonWorks) Trunk Connector Plug, 2-position
10140	RS-485 connector plug, 3-position
10139	I/O connector plug, 6-position
10149	Resistor, 499 ohm, 1%, 0.6w
10138	Battery/ground harness (also includes 6-position power connector)
10148	Adapter, RJ-45 to DB-9 null modem, for serial port to connect to DTE device
10180	Silver satin patch cable, 4 feet (used between adapter and serial port)
10181	Silver satin patch cable, 10 feet (used between adapter and serial port)
10182	Silver satin patch cable, 25 feet (used between adapter and serial port)
MDM-403	On-board auto dial/auto answer 56k modem (see <a href="#">“Replacing the Modem”</a> , below)

## Replacing the Modem



**Caution** Before handling board components, discharge any accumulated static by touching the metal surface of the JACE. For more information, see the [“Static Discharge Precautions”](#) section on page 3.

To replace the modem, proceed as follows:

### Procedure 9 Replacing the on-board modem.

- Step 1** Open the cover of the unit.
- Step 2** Unplug the 6-position power connector. Do not remove the male connector from the wiring harness.
- Step 3** Unplug the RJ-11 telephone wire from the modem’s RJ-11 connector.
- Step 4** Remove the old modem as follows:
- Locate the on-board modem (see [Figure 8](#) on page 22) and note the following:
    - Orientation of the sockets for the pins on the modem. The sockets are two parallel lines. The socket for pin 1 (noted on [Figure 8](#)) is the left-most pin on the bottom line.
    - Orientation of the writing on the modem. Writing on the replacement modem will be the same.
  - Place the blade of a flat-blade screwdriver under the left end of the modem between the pin sockets.
  - Gently pry the modem up about 3 mm (1/8th inch).



**Caution** Do not try to completely remove the modem with this step. Doing so may damage the pins.

- d. Place the blade of the screwdriver under the right end of the modem and gently pry the modem up about 3 mm (1/8th inch).
- e. Repeat steps b–d until the modem is out of its socket.

**Step 5** Insert a new modem as follows:

- a. Locate pin 1 on the modem. If you are reading the writing on the modem, pin 1 is the first pin in the lower left corner. It is marked with a small black dot on the top of the modem.
- b. Locate the socket for pin 1 on the board (see [Figure 8](#)).
- c. Orient the modem so that pin 1 of the modem is over the socket for pin 1.



**Tip** Use the white trace lines on the board to help you align the modem. When the modem is correctly aligned, the trace lines will outline the modem completely.

- d. Push the modem into the sockets using your thumbs. All pins should be properly inserted.

**Step 6** Plug the RJ-11 telephone wire into the modem's RJ-11 connector.

**Step 7** Plug the power connector in and verify normal operation.

## Field Replacement Units

To replace a faulty unit, order from the field replacement units (FRUs) listed in [Table 7](#). An FRU consists of the metal enclosure, PC board, memory, I/O connectors, transformer, and labels assembled as a unit. To replace a faulty modem, order it using the part number listed in [Table 6](#), and see the section “[Replacing the Modem](#)”.

These parts can be ordered from stock, but the replaced part (that which is removed from the JACE-403) must be returned to your regional Tridium office for credit.



- Notes**
- Before ordering an FRU, it is strongly recommended that you contact your normal technical support resource to eliminate the possibility of a software issue or misconfiguration problem.
  - Be sure to contact Tridium for a return authorization (RA) number (see “[Returning a Defective Module,](#)” page 33) before shipping an item for return credit or repair. To allow proper licensing of the replacement unit, please have information ready about the existing unit, including its serial number, model number, and project licensed to, when placing the order.

**Table 7** Field replacement units.

Part Number	Description
R-JACE-403	Field Replaceable Unit, JACE-403
R-JACE-403I	Field Replaceable Unit, JACE-403I

## Replacing an FRU

To replace an FRU in the field, proceed as follows:



**Caution** Before handling board components, discharge any accumulated static by touching the metal surface of the JACE. For more information, see the “[Static Discharge Precautions](#)” section on page 3.

### Procedure 10 Replacing an FRU.

- 
- Step 1** Using the Admin Tool, back up the station database to your PC.
  - Step 2** Open the cover of the unit.
  - Step 3** If any of your I/O points have voltage, turn the devices off or disconnect power to them.
  - Step 4** Turn off building power to the unit. The unit should power down automatically.
  - Step 5** Unplug the 6-position power connector. Do not remove the male connector from the wiring harness.
  - Step 6** Disconnect building power wiring from the transformer (see “[Power Wiring,](#)” page 15).
  - Step 7** Unplug any Ethernet, serial, LON, and modem cables and pull them out of the unit through the adjacent knockouts.
  - Step 8** Unplug all I/O connectors, remove the I/O connectors from their cables (see the Caution that follows), and pull the cables out of the unit through the adjacent knockouts.



**Caution** Be sure to label the I/O wires so that you can attach them to the corresponding terminals in the new unit. The software that runs on the unit expects the terminal position to be the same to collect data from or to control the attached devices.

- Step 9** Remove the unit from its mounting by unscrewing the #10 screws which hold it to the wall.
  - Step 10** Replace the unit, and attach it to the wall with the #10 screws.
  - Step 11** Reconnect building power wiring to the unit (see “[Power Wiring,](#)” page 15).
  - Step 12** Turn on building power to the unit.
  - Step 13** Plug the power connector in and verify normal operation.
  - Step 14** Reconnect any Ethernet, serial, LON, and modem cables.
  - Step 15** Reconnect all I/O connectors and secure them in place.
  - Step 16** If any of your I/O points have voltage, turn the devices back on, or reconnect power to them.
  - Step 17** Using the Admin Tool, install the correct Niagara release and set the date and time.
  - Step 18** Using the Admin Tool, install the new license file.
  - Step 19** Using the Admin Tool, restore the station database and start the station.
-

# Returning a Defective Module

For proper credit on the returned unit, ship the defective module to Tridium within 30 days.

Prior to returning the unit, contact one of the following Tridium offices to obtain a return authorization (RA) number and other instructions. Please provide:

- Product model
- Serial number
- Project currently licensed to
- Nature of the defect

## United States

**Phone:** 804-254-7086, ext. 204

**Return to:**

Tridium, Inc.  
 2248 Dabney Road, Suite F  
 Richmond, VA 23230  
 Attn: Return Department RA# \_\_\_\_\_

## Europe

**Phone:** +44 (0) 1403 740290

**Fax:** +44 (0) 1403 741804

**Return to:**

Tridium Europe Ltd  
 1, The Grainstore  
 Brooks Green Road  
 Coolham  
 West Sussex  
 RH13 8GR  
 United Kingdom  
 Attn: Return Department RA# \_\_\_\_\_

**Email for technical support:**

[supportuk@tridium.com](mailto:supportuk@tridium.com)

**Email for product orders:**

[ordersuk@tridium.com](mailto:ordersuk@tridium.com)

## Asia/Pacific

**Phone:** +65 6887 5154

**Fax:** +65 6887 5342

**Mobile:** +65 9665 6024

**Address:**

Tridium Asia Pacific Pte Ltd  
 101 Cecil Street,  
 #10-11, Tong Eng Building,  
 Singapore 069533  
 Attn: Mr Lim Hoon Chiat, Engineering Manager RA# \_\_\_\_\_

**Email for technical support:**

[hclim@tridium.com](mailto:hclim@tridium.com)

**Sales:** (Australia): **Phone:** +61 7 5539 1211

**Fax:** +61 7 5597 2334

(Japan): **Phone:** +81 044 829 1750

# Certifications

---

## Federal Communications Commission (FCC)

This equipment generates, uses, and can radiate radio frequency energy, and if not installed and used in accordance with the instruction manual, may cause interference with radio communications. It has been tested and found to comply with the limits for a Class A computing device pursuant to Subpart J of Part 15 of FCC Rules, which are designed to provide reasonable protection against such interference when operated in a commercial environment. Operation of this equipment in a residential area may cause interference, in which case, users at their own expense will be required to take whatever measures may be required to correct the interference. Any unauthorized modification of this equipment may result in the revocation of the owner's authority to continue its operation.

## Canadian Department of Communications (DOC)



---

**Note** This Class A digital apparatus meets all requirements of the Canadian Interference-Causing Equipment Regulations.

---



---

**Note** Cet appareil numérique de la classe A respecte toutes les exigences du Règlement sur le matériel brouilleur du Canada.

---

# Declaration of Conformity

## JACE-403 JACE-403I

<b>Application of Council Directive:</b>	89/336/EEC, 92/31/EEC, 73/23/EEC, 93/68/EEC	
<b>Manufacturer's Name:</b>	Tridium, Inc.	
<b>Manufacturer's Address:</b>	3951 Westerre Parkway, Suite 350 Richmond, Virginia 23233 United States of America	
<b>Manufacturer's Representative:</b>	Terry Casey, President Tridium Europe Ltd 1, The Grainstore, Brooks Green Road, Coolham, West Sussex, RH13 8GR United Kingdom	
<b>Product Model Number:</b>	JACE-403I and JACE-403I-UI	
<b>Type of Equipment:</b>	Information Technology Equipment	
<b>EMC Standards Applied:</b>	<b>EN 50081-1:</b>	<b>Emissions</b>
	EN 55022	Power Line Conducted Emissions
	EN 55022	Electric Field Radiated Emissions
	<b>EN 55082-1:</b>	<b>Immunity</b>
	EN 61000-4-2	Electro-Static Discharge
	EN 61000-4-3	Radiated Field Immunity
	EN 61000-4-4	Electrical Fast Transient Immunity
	EN 61000-4-5	Surge Immunity
	EN 61000-4-6	Power Line Conducted Immunity
	EN 61000-4-11	Voltage Dips
	EN 61000-4-11	Voltage Interrupts
	IEC 61010-1	Safety, Requirements Electrical Equip.

I, **Terry Casey**, hereby declare that the equipment specified above conforms to the above Directives and Standards.

Place: Coolham, West Sussex, United Kingdom

May, 2002

Position: President, Tridium Europe Ltd.

# You can help make this document even better!

Please help us make our documentation as useful as possible. Use this form to advise us of errors, descriptions that are not clear, or provide any other helpful information.

**Mail this form to:**

Tridium, Inc.  
3951 Westerre Parkway, Suite 350  
Richmond, Virginia 23233  
Attention: Tridium Documentation Team

**Or fax is to us at:** (804) 747-5204

**Or e-mail your comments to us at:** [documentation@tridium.com](mailto:documentation@tridium.com)

Thank you for taking the time to help us improve our documentation!

## Documentation Comment Form

**Document Title:** \_\_\_\_\_ JACE-403 Installation and Configuration Instructions, Part Number 10308, Rev. 2

**Document Version:** \_\_\_\_\_ *Revised: May 10, 2004*

Page #	Problem Found or Suggested Change

**Your Name:** \_\_\_\_\_

**Your Company:** \_\_\_\_\_