

# EP/2 Keypad and Display Instructions

## Disclaimer

Logic One® and NovarNet® are registered trademarks of Novar Controls Corporation.

The material in this manual is for information purposes only. The contents and the product it describes are subject to change without notice. Novar Controls Corporation makes no representations or warranties with respect to this manual.

In no event shall Novar Controls Corporation be liable for technical or editorial omissions or mistakes in this manual, nor shall it be liable for any damages, direct or incidental, arising out of or related to the use of this manual.

---

Copyright © 2004 by Novar Controls Corporation. All rights reserved.

No part of this manual may be reproduced in any form or by any means without prior written permission from Novar Controls Corporation.

Novar Controls Corporation  
6060 Rockside Woods Blvd., Cleveland, OH 44131  
Tel: 800.348.1235 [www.novarcontrols.com](http://www.novarcontrols.com)

# Contents

## Introduction 1

- Using the EP/2 Keypad 1
- Accessing the EP/2 Display 3
- Using the EP/2 Display 4
  - Creating a Customized Message 5

## Using the Main Menu 7

- Load Control 7
  - Monitoring 8
  - Settings/Parameters 9
  - Schedule 10
- Monitoring Alarms 12
  - Monitoring Functions 12
  - Parameters 13
  - Schedule 14
- History Logs 14
  - Tabular Display 16
  - Report Setup 16
  - Graphical Display 17
  - Point Identification 18
- Module Status 18
  - View Inputs 19
  - View Outputs 19
- Alarm Scan 20
  - Scan for Current Alarms 20
  - View Alarm History Table 21
  - Alarm Report Information 21
- Tools 22
  - EP/2 Configuration 22
  - Diagnostics 25
  - Disk Services 29
- Load Status 30
- Virtual Points 31
- Electrical Demand 31

## Alarm Messages 33

This page intentionally left blank.

## Introduction

The EP/2 module manages the operation of Novar Controls' Logic One<sup>®</sup> Building Management System. The Logic One system is a comprehensive, totally integrated, automated network of intelligent modules designed to control building equipment effectively and manage energy costs economically. The EP/2 is responsible for all communication and control activities within the system.

The EP/2's keypad and display are used to monitor and change system parameters locally.

---

**NOTE!** The keypad and display can only be used to change some parameters. The cursor will only move to those parameters that can be changed with the keypad. Parameters that cannot be changed with the keypad must be changed in the PC.

---

This document explains how to:

- Use the EP/2 keypad.
- Access and use the EP/2 display.
- Access and use the Main Menu options.

It also explains the various alarm messages that can appear if the EP/2 detects a problem with one of the loads.

## Using the EP/2 Keypad

The EP/2 keypad (Figure 1) has 16 keys that can be used to perform all of the tasks necessary for monitoring and/or changing parameters.

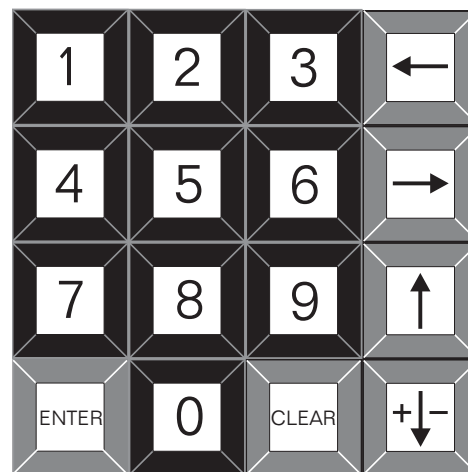

Figure 1. EP/2 keypad's number keys

The following table explains how the various keys function.

| KEYS           | FUNCTION  |
|----------------|---|
| Number keys    | The number keys are used to enter numerical values when changing system settings.   |
| Arrow keys     | The arrow keys are used to: <ul style="list-style-type: none"><li>■ Move the highlighted cursor from one field to another.</li><li>■ Scroll through a series of displays.</li><li>■ Advance through multiple options for a selection.</li></ul>   |
| Enter key      | The Enter key is used to confirm a selection or a number value that has been entered.<br><br><hr/> <b>NOTE!</b> The <b>Enter</b> key must be pressed after a value has been changed and before the cursor is moved to another field. Otherwise, the system reverts to the previous setting. <hr/> |
| Clear key      | The Clear key is the equivalent of an Escape (Esc) key on a PC. It is used to exit one display and return to the previous display. If this key is pressed repeatedly, the system returns to the system information and logon display.   |
| Plus/Minus key | The down arrow key also serves as the plus (+) and minus (–) key, which is used to make a number a positive or negative value.  |

The following table describes, in general, how these keys are used to select options or change parameters.

| <b>FUNCTION</b>  | <b>ACTION(S) REQUIRED</b>   |
|--|---|
| To select an option  | <ul style="list-style-type: none"> <li>■ Use the arrow keys to move the cursor to the appropriate option.</li> <li>■ Press <b>enter</b>.</li> </ul>   |
| To change a setting or value   | <ul style="list-style-type: none"> <li>■ Use the arrow keys to move the cursor to the appropriate field and change a setting</li> <li style="text-align: center;"><i>or</i></li> <li>use the number keys to change a value and the plus/minus key to make the value negative or positive.</li> <li>■ Press <b>enter</b>.</li> </ul>                                   |
| To scroll through a list of options                                      | <ul style="list-style-type: none"> <li>■ Use the down and up arrow keys to scroll vertically through a list of selections.</li> </ul> <p>If the down arrow key is used to scroll through a list and the list extends beyond the bottom of the current display, when the arrow reaches the bottom of the list and is pressed, the display scrolls one full screen.</p> |
| To scroll to the right or left to view additional columns of information | <ul style="list-style-type: none"> <li>■ Use the left and right arrow keys to scroll horizontally through columns that do not fit on the display.</li> </ul> <p>These displays are noted in this manual.</p>  |

A command line sometimes appears at the bottom of a display to provide selection-specific directions.

## Accessing the EP/2 Display

---

**NOTE!** If a download or a system check is in progress, the system cannot be accessed until the download or check is complete.

---

To access the system, the user must:

- Press the appropriate number keys to enter the four-digit access code assigned by the system administrator.
- Press **enter**.

If the code is entered correctly, the display briefly flashes the level of access that is granted before displaying the Main Menu. If the access code is entered incorrectly, the message “Access Denied—Try Again!” is displayed.

---

**NOTE!** If an EP/2 has never received a download, the default access code is **1234**. This access code is not available after the download unless it is programmed to be the access code.

---

The system administrator determines each user's access level when the access code is assigned. There are three levels of access.

| ACCESS LEVEL   | DESCRIPTION   |
|----------------|---|
| Monitor        | The user can monitor most system functions but cannot modify anything except to activate or deactivate timed overrides. |
| Temporary User | The user can monitor all system functions and modify most of them on a temporary basis.                                 |
| Super User     | The user can monitor all system functions and modify all parameters accessible from the keypad and display.             |

### Using the EP/2 Display

The system information and logon display (Figure 2) is always displayed when the keypad and display are not in use. It contains the following information:

- Current time, date, and temperature
- EP/2's module address
- Copyright information
- Novar Controls product information
- System status messages
- System number and name
- Instructions for accessing the system

```
02:00 PM 12/01/97 *70 Degrees
          Novar EP/2 UNIT:01
Copyright (C) 1997 Download Version
          Novar Controls Corporation
[STATUS MESSAGES - SEE DESCRIPTION]
System:   7 Novar Test Sys

          ENTER ACCESS CODE:
```

**Figure 2.** System information and logon display

The screen features a liquid crystal display (LCD) 8 lines by 40 characters long (64 × 240 pixels) with a backlight that turns off automatically if the keypad remains inactive for a user-specified period (up to 99 seconds—the default). The backlight can be reactivated by pressing any key. Information about changing the backlight cutoff time appears in the “Set Clock and Display” section of this document (see “Tools, Diagnostics”).

If Line 3 of the display shows a “Download Version” message, the EP/2 has received a download. If Line 3 shows the message “System Check,” the EP/2 has not yet received a download.

The following system status messages can appear, in reverse video, on Line 5 of the display.

| MESSAGE              | EXPLANATION   |
|----------------------|---|
| Download in Progress | A PC operating with Novar Controls software or a 3.5-inch disk is downloading to the EP/2.  |
| Loading Comm         | A version download is being sent to the communications processor in the EP/2.   |
| Loading Main         | A version download is being sent to the main (control) processor in the EP/2.   |
| System Calling Out   | The EP/2 is calling out alarms to a remote computer.  |
| System Check         | The EP/2 has not yet received its initial system download containing system-specific control data (parameters); therefore, it is not yet controlling the system.                                  |
| System On-Line       | The EP/2 is receiving a call from a computer running Novar Controls software. This message can then be replaced by a more specific message with a higher priority such as “Download in Progress.” |
| Version Check        | There is an error with the main version download. The download must be restarted.   |

If none of these activities is occurring, the system status line remains blank.

### Creating a Customized Message

The system information and logon display can be made to alternate with a customized message display. Each will appear for approximately 5 seconds.

The top two lines of the two displays are the same. The next five lines of the customized display can be used to display a user-specified message created in the system software.

The following procedure can be used to create a customized message.

## EP/2 Keypad and Display Instructions

---

| Step | Procedure  |
|------|--|
| 1    | Double-click on the PC's Novar desktop icon to open the Novar screen.  |
| 2    | Double-click on the <b>ESS32</b> option to open the Logic One Engineering and Support System screen.   |
| 3    | Enter the access code and press <b>enter</b> to display the ESS Menu.  |
| 4    | Continue to enter the appropriate options to access the Function Menu for the EP/2 that is to have the customized message display.   |
| 5    | Type in the number for the <b>User Message for Keypad</b> option at the "Enter a number to either display or modify" prompt.   |
| 6    | Follow the prompts at the bottom of the display to select the appropriate EP/2 and enter or change the customized message (limited to five lines).   |
| 7    | Press <b>enter</b> when the message has been entered. <ul style="list-style-type: none"><li data-bbox="639 888 1427 955">■ The information can be transferred to the EP/2 through Network Monitoring mode or by downloading to the EP/2.</li></ul> |

The message automatically appears after the EP/2 receives it.

---

## Using the Main Menu

The Main Menu (Figure 3) is displayed immediately after a user enters the correct access code. The options offered in this menu are used to access displays that can be used to monitor a system's operation or to change a system's parameters.

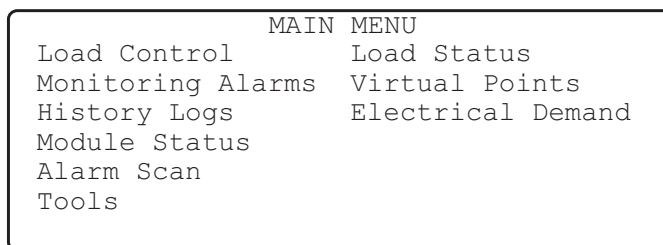

Figure 3. Main Menu display

---

**NOTE!** Figure 3 shows the menu after the EP/2 has received a version download. If the EP/2 has not yet received a download, the only option offered will be Tools. Instructions for downloading a version appear in the “Tools” section of this document.

---

Each of this menu's options are explained in detail on the following pages.

---

### Load Control

Selecting the **Load Control** option from the Main Menu and pressing **enter** opens the Load Directory display similar to the one shown in Figure 4.

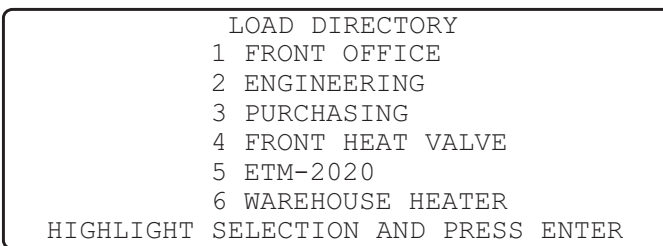

Figure 4. Load Directory display

This directory lists all of the loads currently set up in the system. When the user selects an option and presses **enter**, a Load Menu similar to the one shown in Figure 5 opens.

```
                                LOAD MENU
LOAD: Front Office
TYPE: ELECTRONIC THERMOSTAT
Monitoring
Settings/Parameters
Schedule

                                HIGHLIGHT SELECTION AND PRESS ENTER
```

**Figure 5.** Load Menu display

The Load Menu shows the selected load's name and type and offers the following options:

- **Monitoring**
- **Settings/Parameters**
- **Schedule**

The up and down arrow keys can be used to move the cursor to an option. Pressing **enter** opens the appropriate display based on the option selected (highlighted).

---

**NOTE!** Load parameters are displayed in the same format from one EP/2 display to another, but the actual parameters listed are determined by the type of load. The sample displays shown in this document list the parameters for a standard Electronic Thermostat Module (ETM).

---

### Monitoring

The **Monitoring** option in the Load Menu allows the user to view current control status information for the selected load. The number of monitoring displays provided for a particular load (see sample in Figure 6) depends on the load.

The first display shows the load's name, type, module number, and the current status of several parameters. Each display following the first shows the load's name, its type, and additional parameters. The command line for all monitoring displays reads "Use arrow keys for more info."

The right or down arrow keys can be used to move to the next display. The left or up arrow keys can be used to return to the previous display. At the last display, the right or down arrow key returns the user to the first display.

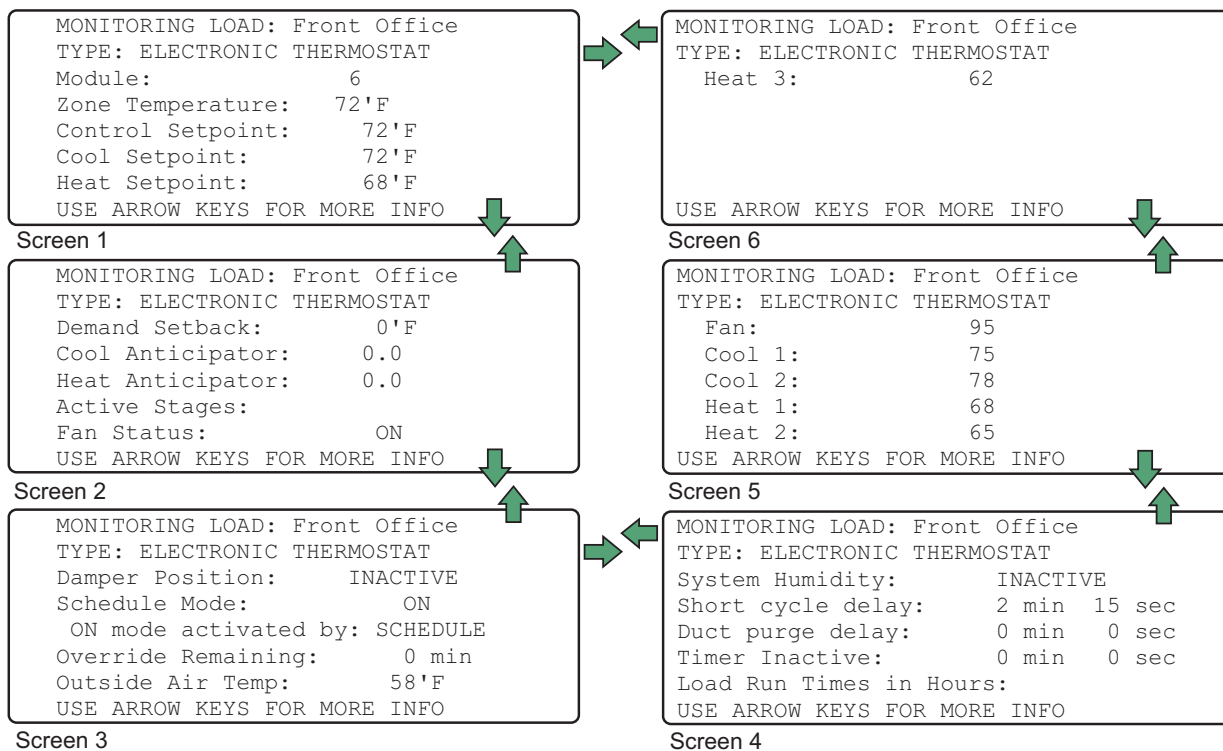

Figure 6. Load monitoring displays for a standard ETM

### Settings/Parameters

The **Settings/Parameters** option in the Load Menu allows the user to change the selected load’s parameters. The number of displays provided for a particular load depends on the load type (see sample in Figure 7). Each display shows the selected load’s name and type. If the load is an ETM, the first display also shows the ETM type.

**NOTE!** Not all the fields can be changed for each load. The highlighted cursor only moves to those fields that can be changed.

The right and left arrow keys can be used to move the cursor from one field to another. If the parameter requires a numerical value, the command line at the bottom of the display indicates an appropriate range of numbers that can be entered (for example, “Enter from 45 to 71.”). The range is based on the parameters of the specific load. The number keys are used to enter the appropriate value. If a parameter offers an option that does not require a numerical value (for example “Active” or “Inactive”), the command line prompts the user to “Use up/down keys to change selection.”

After each parameter has been changed, the user must press **enter** to confirm the change. Pressing **clear** exits the display.

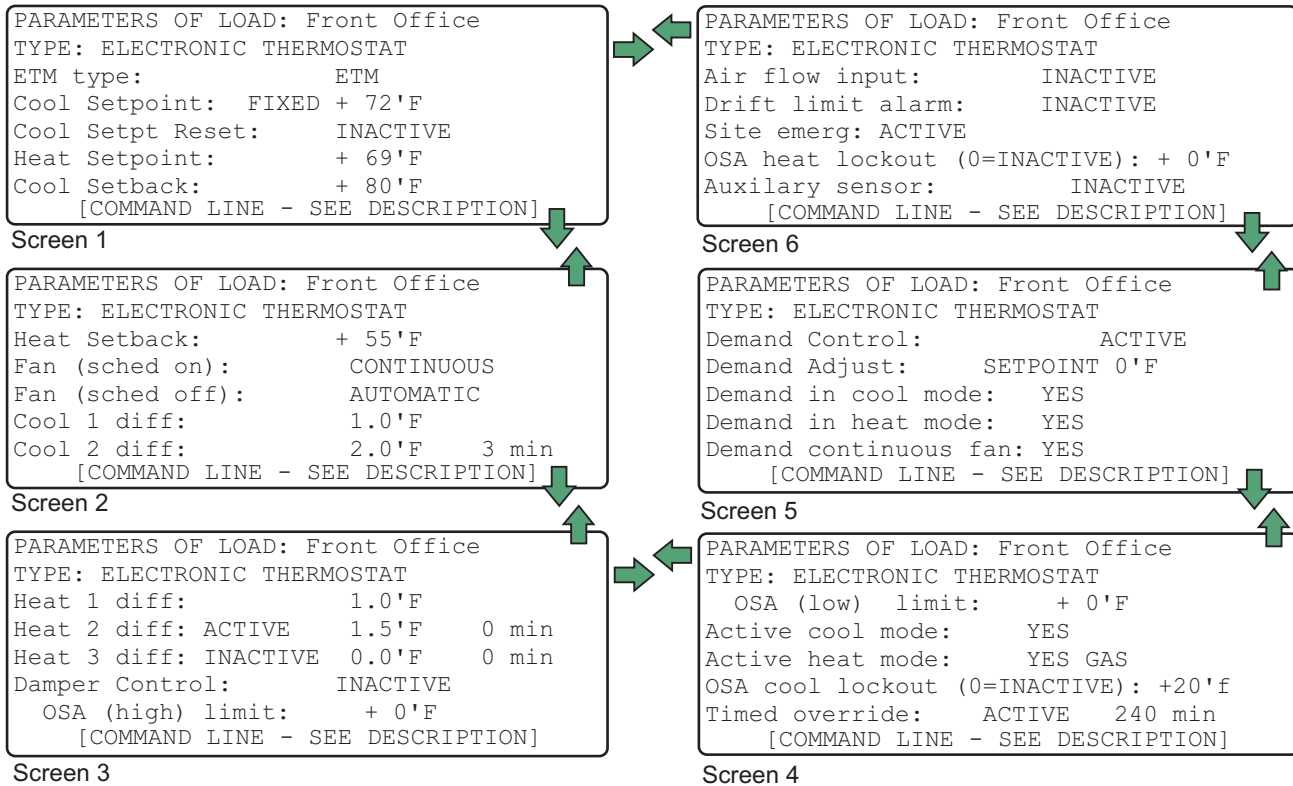

Figure 7. Settings/parameters displays for a standard ETM

### Schedule

The **Schedule** option in the Load Menu allows the user to view, change, add, or delete schedule times in the selected load's operation schedules.

There are two types of schedules:

- Shifted schedules are used to start a schedule before or after a normally scheduled time. The time difference is entered as a plus or minus value (for example, a time difference of 1 hour would be entered as -1:00 or +1:00).
- Normal on/off schedules show the actual starting and stopping time with an A.M. or P.M. following each.

When the schedule display (Figure 8) first opens, it shows the schedule number, its effective dates, three available on and off schedule times and the schedules for the current day ("Today"), the next day ("Tomor"), holiday, and Sunday. The arrow keys can be used to scroll through the remaining days of the week.

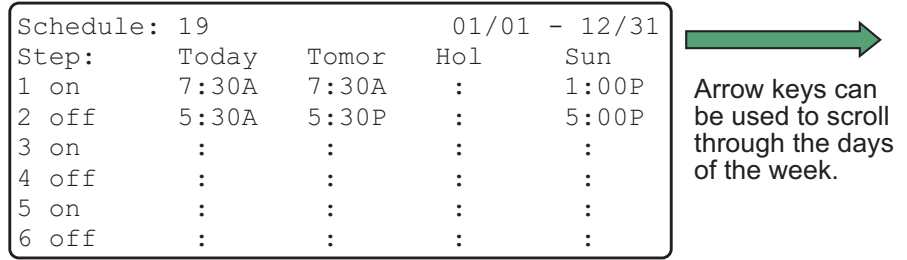

Figure 8. Schedule display

The following procedure should be used to change or add a schedule.

| Step | Procedure  |
|------|--|
| 1    | Move the cursor to the appropriate field.  |
| 2    | Use the number keys on the keypad to enter a new value.  |
| 3    | Press <b>enter</b> to confirm the value entered.   |
| 4    | Use the plus/minus key to enter a plus or minus for a shifted schedule or an A.M. or P.M. for a normal schedule. |
| 5    | Press <b>enter</b> again to confirm the changes.   |

---

**NOTE!** If the user leaves the field without completing *each* of the steps listed in the procedure above, the field returns to its previous value.

---

The following procedure should be used to delete a schedule entry.

| Step | Procedure  |
|------|--|
| 1    | Use the number keys to enter <b>9999</b> in the appropriate field.   |
| 2    | Press <b>enter</b> <i>twice</i> .<br><br><div style="border: 1px solid black; padding: 5px; margin: 5px auto; width: fit-content;"> <p><b>NOTE!</b> Do <i>not</i> press the plus/minus key.</p> </div> |
| 3    | Press <b>Clear</b> to exit the display.  |

### Monitoring Alarms

Selecting the **Monitoring Alarms** option from the Main Menu opens the Monitor Alarm Directory (Figure 9).

```
MONITOR ALARM DIRECTORY
  1 ALARM ONE
  2 ALARM TWO
  3 ANALOG INPUT
  4 OUTDOOR HUMIDITY
  5 LIGHTS
  6 ALARM SIX
HIGHLIGHT SELECTION AND PRESS ENTER
```

**Figure 9.** Monitor Alarm Directory display

This directory lists of all the monitoring alarms currently set up in the system. When the user highlights an alarm and presses **enter**, the Monitor Alarm Menu (Figure 10) opens.

```
MONITOR ALARM MENU
MONITORING ALARM:  ALARM ONE

Monitoring Functions
Parameters
Schedule

HIGHLIGHT SELECTION AND PRESS ENTER
```

**Figure 10.** Monitoring Alarm Menu display

The display shows the name of the selected alarm and offers the following options:

- **Monitoring Functions**
- **Parameters**
- **Schedule**

The up and down arrow keys can be used to select an option. Pressing **enter** opens the appropriate display based on the option selected.

---

#### Monitoring Functions

The **Monitoring Functions** option allows a user to view the current alarm status for the selected monitoring alarm but does not allow the user to make changes.

Several displays provide current alarm status information. The number of displays depends on the alarm type. Each display lists the name of the monitoring alarm and shows the “Monitoring Functions” option is in use (Figure 11). The displays also list several parameters and show their current status. The command line reads “Use arrow keys for more info.”

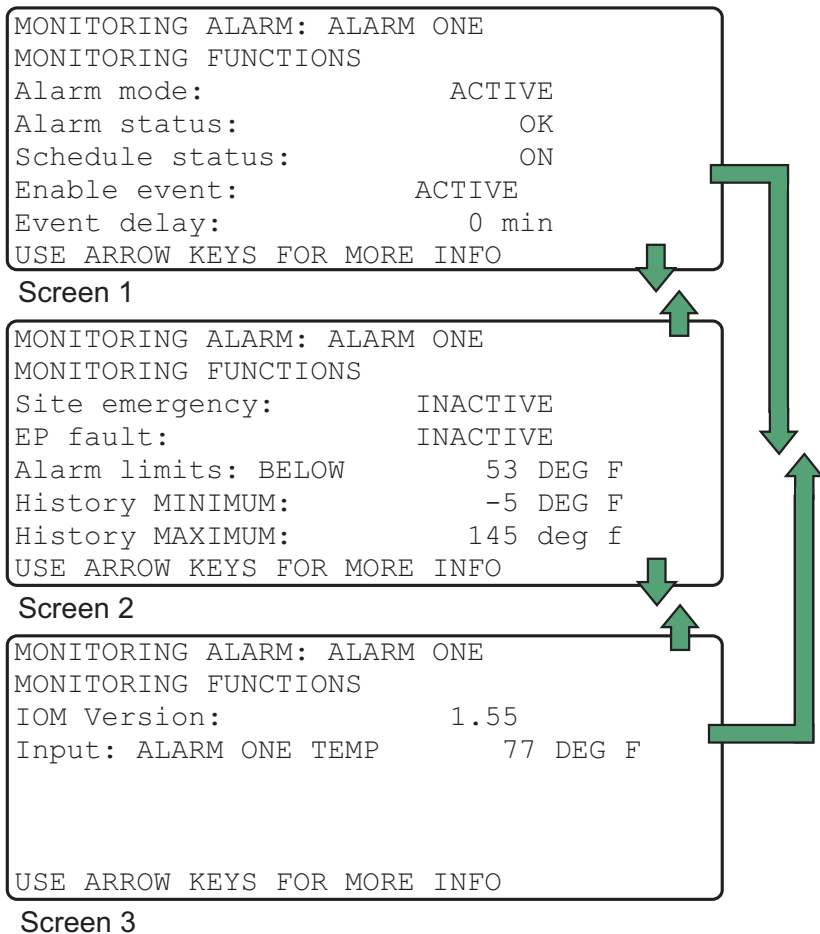

Figure 11. Monitoring Alarm monitoring displays

The right or down arrow keys advance to the next display. The left or up arrow keys return to the previous display. At the last display, the right or down arrow key returns to the first display. Pressing **clear** exits the display.

**Parameters**

The **Parameters** option can be used to access a variety of displays where the user can view and/or change monitoring alarm parameters to change the selected alarm’s operation. The number of displays that can be accessed and the parameters that are displayed depend on the alarm type.

Each display lists the name of the monitoring alarm and shows that the “Parameters” option is in use (Figure 12).

**NOTE!** Not all the fields can be changed for each alarm. The highlighted cursor only goes to those fields that can be changed.

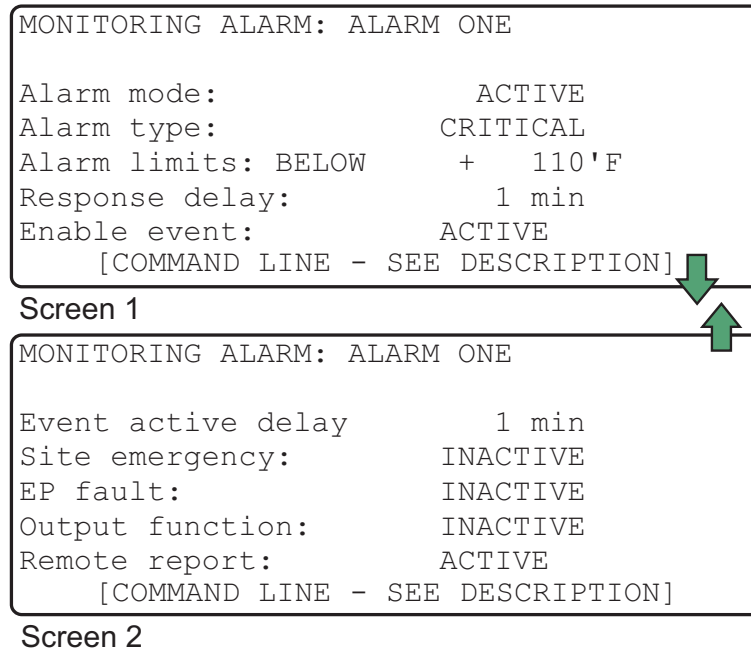

**Figure 12.** Monitoring Alarm parameters displays

The right and left arrow keys can be used to move between fields. For each selection requiring a numerical value, the command line at the bottom of the display indicates an appropriate range of numbers that can be used (for example, “Enter from 20 to 120”). The range is based on a specific load’s parameters. The number keys should be used to enter the value. Once it has been entered, the user must press **enter** to confirm the change.

When a field requires a user to select an option that is not a numerical value (for example **Active** versus **Inactive**), the up and down arrow keys can be used to view and select the appropriate option. The user must then press **enter** to confirm the change.

Pressing **clear** exits the display.

---

### Schedule

The monitoring alarm schedules are viewed and adjusted the same way the load schedules are viewed and adjusted (see “Load Control, Schedule”).

---

## History Logs

Selecting the **History Logs** option from the Main Menu and pressing **enter** opens the History Logs Directory (Figure 13), which lists all existing data and meter/counter logs currently in the system.

```
HISTORY LOGS
METER LOG
BOILER ROOM
FRONT OFFICE
PRIMARY PUMPS
HEATING PUMPS
BACK FAN
USE ARROW KEYS TO SELECT LOG
```

**Figure 13.** History Logs Directory display

Using the arrow keys to select an option from the directory and pressing **enter** displays the History Logs Menu (Figure 14). The top half of the menu shows settings for several log parameters that were programmed in Novar Controls' software.

```
LOG: PRIMARY PUMPS
 256 entries every 60 min. 00sec.
Continuous running
Offset time: 00:00:00
TABULAR DISPLAY      REPORT SETUP
GRAPHICAL DISPLAY
POINT IDENTIFICATION
  USE ARROW KEYS TO SCROLL DISPLAY
```

**Figure 14.** History Logs Menu display

- Line 1 of the display shows the data log's name.
- Line 2 shows the number of entries to be logged for each point and how often an entry is recorded in the log.

When the log reaches the maximum number of entries, the oldest data is dropped and replaced with a new reading.

- Line 3 shows if the logging is to run continuously or to stop at a defined date and time.
- Line 4 shows if there is an offset time.

The offset time changes the actual time data logs are recorded. This feature is used to synchronize the data log with the clock so entries are at desired intervals. For an additional explanation of the parameters on this display, refer to Novar Controls' *ESS32 Programming Manual* (Doc. No. TD-0700).

The remaining lines of the menu offer the following options:

- **Tabular Display**
- **Report Setup**
- **Graphical Display**
- **Point Identification**

### Tabular Display

The **Tabular Display** option allows the user to view the values for the eight available data log points with the time interval of the entry to the left and the values in column format (Figure 15). Above each column is the unit of measurement for the data.

| LOG DATA FOR: PRIMARY PUMPS |         |         |         |       |
|-----------------------------|---------|---------|---------|-------|
| Time:                       | 1) %-on | 2) %-on | 3) %-on | 4) 'F |
| 11:00:00                    | 0       | 0       | 0       | 65    |
| 12:00:00                    | 0       | 0       | 0       | 65    |
| 13:00:00                    | 0       | 0       | 0       | 66    |
| 14:00:00                    | 0       | 0       | 0       | 66    |
| 15:00:00                    | 0       | 0       | 50      | 67    |

USE ARROW KEYS TO SCROLL DISPLAY



Arrow keys can be used to scroll through other log points.

**Figure 15.** History logs tabular display

The left and right arrow keys can be used to scroll through the eight data log points. The up and down arrow keys can be used to scroll through the time entries. Pressing **clear** exits the display.

### Report Setup

A printer can be connected to the RS-232 port of an EP/2 to print alarms and data logs directly from the EP/2. Refer to the “Tools, EP/2 Configuration” section in this manual for a description of how to activate this port for printing.

The **Report Setup** option opens the display shown in Figure 16.

| LOG REPORT SETUP            |          |
|-----------------------------|----------|
| RS-232 port print interval: | INACTIVE |

USE UP/DOWN KEYS TO CHANGE SELECTION

**Figure 16.** History Logs Report Setup display

The user can use the options provided in the RS-232 PORT PRINT INTERVAL field to indicate when a data log report is to be printed. The following options are offered:

- **Inactive** (no report will be printed)
- **1/4 Hour**
- **Hourly** (prints at the top of the hour)
- **Daily** (prints at midnight each day)
- **Monthly** (prints at midnight on the first day of the month)

Once the option is selected, the user must press **enter** to confirm the selection before exiting this display. Pressing **clear** exits the display.

**Graphical Display**

The **Graphical Display** option in the History Logs Menu opens the Graphic Point Selection display (Figure 17), which lists the eight points available for that data log.

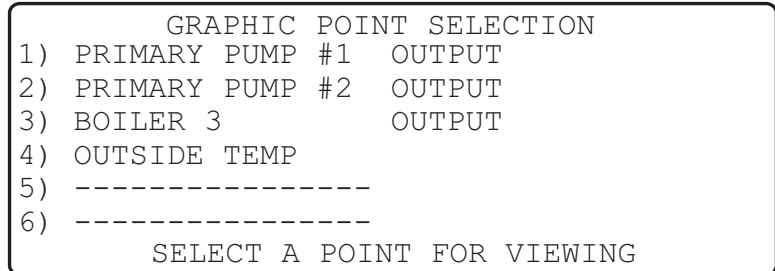

**Figure 17.** History Logs Graphic Point Selection display

Using the up and down arrow keys to select a specific point and pressing **enter** displays that point’s entries in a graph (Figure 18). Pressing **clear** exits the display.

Y axis shows the range of values.

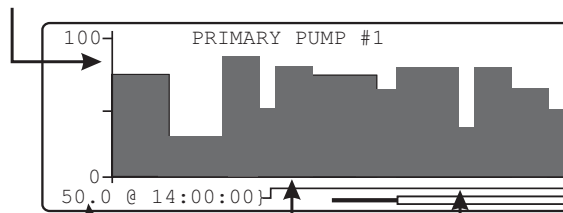

The data log pointer can be moved along the graph using the right and left arrow keys.

Number shows the value and time of the data log where the pointer is currently located.

X axis shows data log entries.

Graph view indicator shows how much data log history is currently being viewed. It moves as the pointer is moved.

**Figure 18.** History logs graphical display

### Point Identification

The **Point Identification** option opens the display shown in Figure 19, which provides the following information:

- Data log point by number and name.
  - A description of the type of point (for example, temperature input or output).
  - The value of the point being recorded.
- For inputs, this value can be the highest value or the lowest value the input reaches during the interval, the average value of the input during the interval, or the sample (instantaneous) value of the input at the time that it is recorded.
- For outputs, the value can be percent on (the average amount of time that the point is on during the interval) or sample (an indication of whether the point was on or off at the time that it was recorded).

|    |                 |        |            |
|----|-----------------|--------|------------|
| 1) | PRIMARY PUMP #1 | OUTPUT | PERCENT-ON |
| 2) | PRIMARY PUMP #2 | OUTPUT | PERCENT-ON |
| 3) | BOILER 3        | OUTPUT | PERCENT-ON |
| 4) | OUTSIDE TEMP    |        | AVERAGE    |
| 5) | -----           |        |            |
| 6) | -----           |        |            |
| 7) | -----           |        |            |
| 8) | -----           |        |            |

Figure 19. History logs point identification display

Pressing **clear** exits the display.

---

### Module Status

Selecting the **Module Status** option from the Main Menu opens a display that lists all of the modules set up in the system (Figure 20).

The up and down arrow keys can be used to scroll through the list one module at a time. The left and right arrow keys can be used to jump between displays.

| MODULE NAME                     | ADDR | TYPE | COMM |
|---------------------------------|------|------|------|
| IOM-1 A MECH RM                 | 0    | IOM  | i 0  |
| IOM-2 A MECH RM                 | 1    | IOM  | i 0  |
| IOM-3 CENTRAL                   | 3    | IOM  | i 0  |
| IOM-4 CENTRAL                   | 4    | IOM  | i 0  |
| ETM ONE                         | 14   | ETM  | i 0  |
| VAV-4020                        | 15   | VAV  | i 0  |
| USE ARROW KEYS TO SELECT MODULE |      |      |      |

Figure 20. Module listing display

The “i” located just to the left of the COMM column in Figure 20 represents inactive. A “c” in this field would represent communication loss. If this field is blank, communications are active and operating normally. The COMM column increments if the module is in communication loss. These fields cannot be accessed from the EP/2 keypad.

Selecting a specific module for viewing and pressing **enter** displays the Module Menu (Figure 21) offering two options:

- **View Inputs**
- **View Outputs**

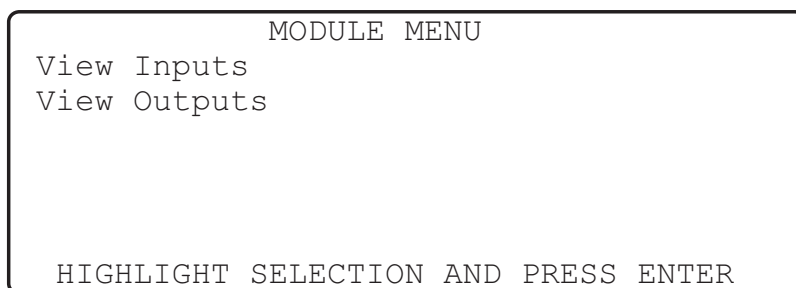

**Figure 21.** Module Menu display

### View Inputs

The input display (see sample in Figure 22) shows the number and name of the input and indicates if the input is analog (ANA) or digital (DIG). The column farthest to the right shows the current value of the input (“open” or “closed” for digital inputs). Analog values show the current value based on how the input is programmed. If an analog value is shown as “open,” an open fault exists.

| #                             | INPUT NAME       | TYPE | VALUE |
|-------------------------------|------------------|------|-------|
| 1                             | ZONE TEMPERATURE | ANA  | OPEN  |
| 2                             | AIR FLOW SENSOR  | DIG  | OPEN  |
| 3                             | AUXILIARY SENSOR | ANA  | OPEN  |
| 4                             | PRESSURE DIFF SW | DIG  | OPEN  |
| 5                             | COOL 2           | DIG  | OPEN  |
| 6                             | HEAT 2           | DIG  | OPEN  |
| USE ARROW KEYS TO SCROLL LIST |                  |      |       |

**Figure 22.** Module status view input display

Pressing **clear** exits the display.

### View Outputs

The output display (see sample in Figure 23) is displayed in the same format as the input display. The first three columns on the left display the output’s number, name, and type (analog or digital). The column to the right shows the status of the load (“on” or “off” for digital values). Analog values show the current value based on how the output is programmed.

| # | OUTPUT | NAME | TYP | VAL |
|---|--------|------|-----|-----|
| 1 | COOL   | 2    | DIG | OFF |
| 2 | COOL   | 1    | DIG | OFF |
| 3 | FAN    |      | DIG | OFF |
| 4 | HEAT   | 1    | DIG | OFF |
| 5 | HEAT   | 2    | DIG | OFF |
| 6 | DAMPER |      | DIG | OFF |

USE ARROW KEYS TO SCROLL LIST

Figure 23. Module status view output display

Pressing **clear** exits the display.

---

## Alarm Scan

Selecting the **Alarm Scan** option from the Main Menu opens the Alarm Scan and View menu, which offers the following options:

- **Scan for Current Alarms**
  - **View Alarm History Table**
  - **Alarm Report Information**
- 

### Scan for Current Alarms

The **Scan for Current Alarms** option displays active alarms in chronological order (see sample in Figure 24). For each alarm, it shows the alarm's date and time, the number and name of the EP where the alarm occurred, and the alarm type.

| CURRENT ALARM TABLE            |       |        |          |   |
|--------------------------------|-------|--------|----------|---|
| 01/26/98                       | 09:19 | ALARM: | SYST-EP: | 1 |
| MASTER CONTROLLER Power Recvry |       |        |          |   |
| 01/20/98                       | 09:40 | ALARM: | SYST-EP: | 1 |
| MASTER CONTROLLER Slave Net Er |       |        |          |   |
| 01/20/98                       | 09:36 | ALARM: | SYST-EP: | 2 |
| ALARM PANEL EP COMM LOSS       |       |        |          |   |

Figure 24. Current Alarm Table

The arrow keys can be used to scroll through the list. Pressing **clear** exits the display.

---

### View Alarm History Table

The **View Alarm History Table** option displays the Alarm History Table (Figure 25), which lists both current alarms and alarms that are no longer current. The format of the Alarm History Table is the same as the Current Alarm Table.

| ALARM HISTORY TABLE            |       |        |          |   |
|--------------------------------|-------|--------|----------|---|
| 01/20/98                       | 09:40 | ALARM: | SYST-EP: | 1 |
| MASTER CONTROLLER Slave Net Er |       |        |          |   |
| 01/20/98                       | 09:40 | ALARM: | SYST-EP: | 2 |
| ALARM PANEL EP COMM LOSS       |       |        |          |   |
| 01/19/98                       | 09:32 | ALARM: | SYST-EP: | 1 |
| MASTER CONTROLLER Power Recvry |       |        |          |   |

Figure 25. Alarm History Table

Pressing **clear** exits the display.

### Alarm Report Information

The **Alarm Report Information** option in the Alarm Scan and View menu can be used to access a display similar to the one shown in Figure 26.

|                                      |
|--------------------------------------|
| Reset redial timer: NO               |
| USE UP/DOWN KEYS TO CHANGE SELECTION |

Figure 26. Alarm Report Information display

The RESET REDIAL TIMER field can be used to indicate if a pending alarm should be called out immediately. The auto redial interval, which is programmed in Novar Controls' software, specifies the amount of time the software waits to redial to call out an alarm if the alarm has not been called out successfully.

If an alarm is pending, a time value appears beneath the RESET REDIAL TIMER field on this display. To override the timer to call out the alarm immediately, the user can:

- Use the up and down arrow keys to change the option to **Yes**.
- Press **enter** to confirm the change.

This resets the timer to zero and redials. If the call is successful, the timer does not appear again on the display for that alarm. If it is unsuccessful, the timer returns to the programmed redial time and restarts the countdown to the next call out.

Pressing **clear** exits the display.

### Tools

Selecting the **Tools** option from the Main Menu opens the Tools Menu, which offers the following options:

- **EP/2 Configuration**
  - **Diagnostics**
  - **Disk Services**
- 

#### EP/2 Configuration

---

**NOTE!** Changes to the EP/2 configuration should be made in Setup Mode *by qualified personnel only* (i.e., the installation contractor or Novar Controls dealer). To place the EP/2 in Setup Mode, remove the EP/2 electronics, *record the address switch settings*, and move all of the address switches to the off position. Place the electronics back onto the base. The unit number should show as 255. Make the necessary changes according to the instructions that follow. Remove the EP/2 electronics again, reset the address switches to their original settings, and place the electronics back on the base.

---

The **EP/2 Configuration** option allows the user to:

- View and modify the parameters for the EP/2's communication network (the configurations for the LAN, RS-232 port, and Ethernet).
- Set the time and date
- Change the display contrast.
- View the current software version information.

The number of displays that can be accessed depends on the communication method being used. Typically, two displays would be available. If Ethernet is being used (Figure 27), two additional displays allow the user to view settings and/or make changes.

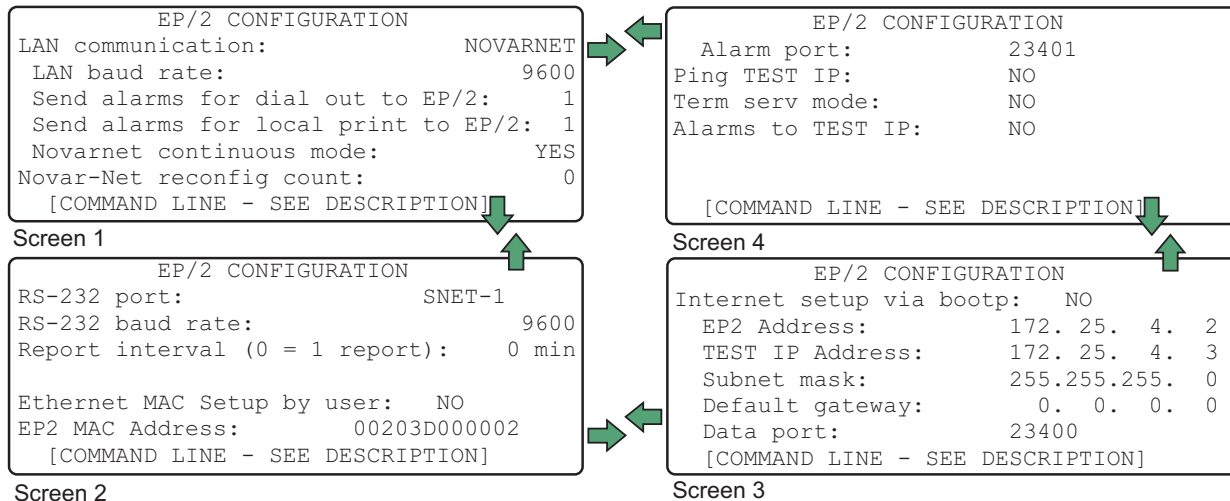

**Figure 27.** EP/2 Configuration (with Ethernet) displays

The first EP/2 Configuration display lists the following parameters:

- LAN communications

Two options are offered for LAN communications:

- **MAS/SLV** (master/slave)
- **NovarNet**

If the **MAS/SLV** option is selected, the user can move immediately to the second display to make selections.

---

**NOTE!** A third option, **MOD2**, refers to one type of system application, a single EP/2 and Manager’s Alarm Panel installation where the Manager’s Alarm Panel uses all of the features of its keypad and display. This option should *not* be selected unless it is appropriate for the system’s application. To obtain information about this application, contact Novar Controls’ Technical Support at (800) 348-1236.

---

- LAN baud rate

This parameter applies to NovarNet<sup>®</sup> only and should be set at 9600 baud rate.

- Send alarms for dial out to EP/2

This parameter is listed for viewing purposes only. It must be changed from Novar Controls’ software. It shows the address of the EP/2 that can dial out alarms and is always the master EP/2.

- Send alarms for local print to EP/2

This parameter is for viewing only. Changes must be made from Novar Controls' software.

The parameter shows the number of the EP/2 to which the local printer is connected. "Local print" refers to a printer that is connected to the RS-232 port of any EP/2 in the system for printing alarms and/or data logs.

- NovarNet continuous mode

This parameter should be set to **Yes** unless Novar Controls' Technical Support instructs otherwise.

- NovarNet reconfig count

This parameter is a diagnostic tool that refers to the number of times NovarNet has attempted to reconfigure.

The following parameters appear on the next EP/2 Configuration display.

- RS-232 port

This parameter and the two that immediately follow it refer to the RS-232 port on the EP/2. The RS-232 port can be configured to print alarms or it can be configured for Novar Controls' direct-connect communication option that allows the user to communicate with a computer workstation for monitoring and alarm reporting. It offers the following option:

— The **SNET-1** option is used for direct-connect communication. After this feature is selected, the baud rate must be set to 9600. The alarms report through this port, not through the internal modem.

— The **Local Alarm** option prints alarms through the RS-232 port. The baud rate should be set to 9600 after this option is selected.

— The **Modem** option is intended for a future enhancement and is currently inactive.

— The **Inactive** option is used if the RS-232 port of the EP/2 is not used.

- RS-232 baud rate

The baud rate should be set to 9600 to match the serial port speed of most computers. It is used with the **SNET-1** and **Local Alarm** options.

- Report interval (0 = 1 report)

This parameter is for viewing only. It must be changed from Novar Controls' software. The interval can be set to report every 1 to 5 minutes or can be set to zero to report only once.

- Internal modem

This parameter is only available if the EP/2 is in Setup Mode. For a standard modem or no modem, the user should select 202; for the 2400-baud S-Modem, the user should select 212.

For information about the Ethernet selections on the EP/2 Configuration displays, refer to existing Novar Controls' technical literature on Ethernet, available from any authorized Novar Controls representative.

---

### Diagnostics

The **Diagnostics** option in the Tools Menu can be used to open the Diagnostics Menu (Figure 28), which offers the following options:

- **Set Clock/Display**
- **Software Status**
- **Communication Ports**
- **FIFO Test**
- **Memory Dump**
- **NCL Program Status**

```
DIAGNOSTICS MENU
Set Clock/Display
Software Status
Communication Ports
Fifo Test
Memory dump
NCL Program Status
HIGHLIGHT SELECTION AND PRESS ENTER
```

**Figure 28.** Diagnostics Menu

These options can be used to access displays where a number of system functions can be set or where the user can view information not found elsewhere in the EP/2 displays.

---

**NOTE!** With the exception of the **Set Clock/Display** option, only a qualified installation contractor or authorized Novar Controls' dealer should use the options in the Diagnostics Menu to change parameters.

---

### **Set Clock and Display**

The Set Clock/Display Parameters display (Figure 29) allows the user to change the time, date, and display settings (including the cutoff time for the backlight). The user must press **enter** after each setting is changed.

```
CLOCK/DISPLAY PARAMETERS
Time Set:          15:20:00
Date Set:          01/26/98
Light Time:        99 sec.
Daylight Savings Time: YES
Display Contrast   7

[COMMAND LINE - SEE DESCRIPTION]
```

**Figure 29.** Clock/Display Parameters display

- The time setting is based on a 24-hour clock (military time). When the cursor is moved to the TIME SET field, the command line says “Enter 24 hr. time setting.” The time should be entered in hour, minutes, and seconds.

---

**NOTE!** The time does not advance while this display is open. To advance the time, the user must exit this display.

---

- The DATE SET field is used to set the current date. When the cursor is in this field, the command line reads “Enter month/day/year.” The appropriate number for the month, the day and the last two digits of the year should be entered.
- The LIGHT TIME field is used to designate the number of seconds the display’s backlight is to remain lit when the keypad is not in use. The command line says “Enter light-on time to 99 secs.” The default setting is 99 seconds.
- The DAYLIGHT SAVINGS TIME field is used to indicate if the system is to automatically adjust its clock based on daylight savings time (**Yes**) or not (**No**).
- The DISPLAY CONTRAST field is used to adjust the contrast (brightness) level of the display. Fifteen levels are offered (1 = brightest; 15 = darkest).

Pressing **clear** exits the display.

---

### **Software Status**

The Software Status display (Figure 30) shows information pertaining to current PROM versions and downloaded program versions of Novar Controls’ software. It also indicates whether the downloaded files were received successfully. This display is for viewing only.

```
Software status:      Address switch:00
Main rom:  1832 crc: 961
Comm rom:  1832 crc:D7E3
Main ram:  1832 loaded 15:31 Jul 29 97
Comm ram:  1832 loaded 15:26 Jul 29 97
Load files: loaded ok   11:57 11/18/97
Main envelope count:  0  max:  0
Comm envelope count:  0  max:  0
```

**Figure 30.** Software Status display

Pressing **clear** exits the display.

---

### **Communication Ports**

The Communication Ports display (Figure 31) shows information pertaining to the communication configuration of the EP/2. This display is for viewing only; no changes can be made. These parameters are set in Novar Controls' software.

```
Internal Modem:      NOVAR-202
Internal modem baud rate:  1165
Internal modem status:  READY
RS-232 port:        SNET-1
RS-232 baud rate:    9600
RS-232 status:      READY
E-Net Startup state:  READY
free packs:         40
```

Screen 1

```
lowest pack:        31
ok pings:           0
failed pings:       0
Master port:        19
Slave nbr:          1
  slave port:       65535
  slave flags:      0
  slave state:      255
```

Screen 2

**Figure 31.** Communication Ports displays

Pressing **clear** exits this display.

---

### **FIFO Test and Memory Dump**

---

**NOTE!** The **FIFO Test** and **Memory Dump** options are included in the system as diagnostic tools. They should be used only on instructions from Novar Controls' Technical Support personnel.

---

### NCL Program Status

The **NCL Program Status** option only applies if Novar Custom Language (NCL) programs are in use in the system.

When the **NCL Program Status** option is selected from the Diagnostics Menu, an overview of the NCL program status is displayed (Figure 32). The first column of the display lists all of the NCL programs created in the system.

| NCL PROGRAM | RUN STAT | ERR CODE | CRC  |
|-------------|----------|----------|------|
| Test1       | 0010     | 0000     | 0000 |
| NCL Prog 2  | 0010     | 0000     | 0000 |

USE ARROW KEYS TO SCROLL LIST

**Figure 32.** NCL Program status

The RUN STAT column, shows a code representing the runtime status of the program. The following table lists the codes that could appear in this column.

| STATUS CODE | DEFINITION                |
|-------------|---------------------------|
| 01          | Exec/halt program control |
| 02          | Program currently running |
| 04          | Program fault             |
| 08          | Floating point fault      |
| 10          | Terminate program         |
| 20          | Program asleep flag       |
| 40          | Critical fault            |
| 00          | Active program context    |

The ERR CODE column shows the code of any errors that occurred when the program was running. For a full description of the error codes refer to Novar Controls' *Novar Custom Language (NCL) Programming Instructions*, available through any authorized Novar Controls' representative.

The CRC column refers to the Cyclic Redundancy Check. This number is usually only useful if the CRC on the EP/2 is compared to the CRC in the Novar Controls software to make sure they match. If the CRC numbers match, both are running the same program.

Moving the cursor to a specific program and pressing **enter** displays more detailed information about that program (Figure 33), including a description of its run status code and the error code. This display is for viewing only; no changes can be made.

```
NCL Program: Test1                CRC: 0000
Run Status:                        TERM
Error State: NO ERROR
```

**Figure 33.** NCL Program detail

Pressing **clear** exits the display.

---

### Disk Services

The third option offered on the Tools Menu, **Disk Services**, opens the Disk Services display (Figure 34), which can be used to initiate a download from the EP/2's built-in 3.5-inch floppy drive. This download can be done directly to the user's local EP/2 or to another EP/2 on the network.

```
                DISK SERVICES
Disk operation:      LOAD EP2 ALL
EP/RC unit to operate on:  0
Data rate:          500K

Disk status:  READY

                USE UP/DOWN KEYS TO CHANGE SELECTION
```

**Figure 34.** Disk Services display

---

**NOTE!** The DISK OPERATION field defaults to Load EP2 All. This option should not be changed. Do not use one of the other disk operations.

---

The following procedure should be used to download data.

| Step | Procedure   |
|------|---|
| 1    | <p>Insert the disk containing the download data into the floppy drive of the EP/2.</p> <ul style="list-style-type: none"> <li>■ When the Disk Services display opens, the cursor is located in the EP/RC UNIT TO OPERATE ON field.</li> <li>■ The DISK OPERATION field should say Load EP2 All to make a version download (Main, Comm, Load Change).</li> </ul> |
| 2    | <p>Enter a number from 1 to 32 to indicate the address of the EP/2 that is to receive the download.</p> <ul style="list-style-type: none"> <li>■ Enter zero (0) if an EP/2 is not selected.</li> </ul>  |
| 3    | Press <b>enter</b> to confirm the selection.  |
| 4    | Press <b>clear</b> to start the download and return to the Tools Menu.  |

The user can monitor the download's progress by selecting the **Disk Services** option from the Tools Menu and checking the DISK STATUS field.

- "Ready" indicates the system is prepared to receive the download.
- "Loading" means the download is in progress.
- An error message indicates a problem has occurred during the download.

Pressing **clear** exits the display.

## Load Status

Selecting the **Load Status** option from the Main Menu and pressing **enter** opens the Load Status display (Figure 35), which lists the following information for each of the system's loads:

- Control input value
- Output status
- Operating setpoint value
- Schedule status
- Alarm status
- Input status

This display is provided for viewing purposes only; no changes can be made.

| Load                | Ctrl In | Output |
|---------------------|---------|--------|
| 1 FRONT OFFICE      | : 75    | ON     |
| 2 ENGINEERING       | : 70    | ON     |
| 3 PURCHASING        | : ----  | ON     |
| 4 FRONT HEAT VALVE: | OPENF   | OFF    |
| 5 ETM-2020          | : 74    | OFF    |
| 6 WAREHOUSE HEATER: | 70      | OFF    |
| 7 VAV-4020          | : ----  | ON     |



Arrow keys can be used to scroll through additional load status information.

**Figure 35.** Load Status display

The right and left arrow keys can be used to scroll through the columns. The up and down arrow keys can be used to scroll through the list of loads.

When the display opens, the load number and name are on the left side of the display. To their right, the control input value and the output status (if applicable) are shown. When a user presses the right arrow key, the control input column continues to show, but the operating setpoint value replaces the output status. If the right arrow is pressed again, both the control input column and the operating setpoint value are replaced by columns showing the load's scheduled status (on or off) and alarm status (if a load is in an alarm state or not). If the user continues to press the right arrow key, the status of each of the eight possible local inputs for each IOM type load is displayed.

Pressing **clear** returns to the Main Menu.

---

### Virtual Points

Selecting the **Virtual Points** option from the Main Menu and pressing **enter** displays all of the virtual points set up in the system (Figure 36). This display is for viewing only, no changes can be made.

| # | VIRTPT NAME      | TYPE  | VALUE       |
|---|------------------|-------|-------------|
| 1 | Average temp     | ANALG | 72.3 Deg F. |
| 2 | AH-6 Mixed Setpt | ANALG | 0.0 Deg F.  |

USE ARROW KEYS TO SCROLL LIST

**Figure 36.** Virtual points display

The # and VIRTPT NAME columns show the number and name of each virtual point. The TYPE column indicates if the point is analog or digital. The VALUE column shows the value of the virtual point and its unit of measurement.

The up and down arrow keys can be used to scroll through the list of virtual points.

Pressing **clear** returns to the Main Menu display.

---

### Electrical Demand

Selecting the **Electrical Demand** option from the Main Menu and pressing **enter** opens the Electrical Demand Status display (Figure 37), which provides the current electrical demand values and a 24-hour log of demand usage. This display is for viewing only, no changes can be made.

| ELECTRICAL DEMAND STATUS |       |                     |       |       |     |
|--------------------------|-------|---------------------|-------|-------|-----|
| POWER:                   | 119KW | TARGET:             | 750KW |       |     |
| DEMAND:                  | 133KW | SHED:               | 0%    |       |     |
| 24 HOUR LOG (KW)         |       | Start date: 1/26/98 |       |       |     |
| 4:45p                    | 142   | 3:45p               | 134   | 2:45p | 127 |
| 4:30p                    | 142   | 3:30p               | 134   | 2:30p | 142 |
| 4:15p                    | 142   | 3:15p               | 134   | 2:15p | 142 |
| 4:00p                    | 134   | 3:00p               | 127   | 2:00p | 142 |

**Figure 37.** Electrical Demand Status display

The top portion of this display shows the current values for each of the following items:

- *Power* is the instantaneous reading of power consumption, updated every 30 seconds.
- *Target* is the programmed demand target value.
- *Demand* is the current value of the 15-minute integrated (average) demand. It is updated every 30 seconds and logged into the 24-hour log every 15 minutes.
- *Shed* shows the percentage of loads that are currently being shed to keep the demand below the target.

The next line of the display shows the start date for the 24-hour log.

The bottom of the display represents a 24-hour log showing demand history for the past 24 hours in 15-minute intervals. This information is helpful for tracking demand periods during the day.

Any of the arrow keys (left, right, up, down) can be used to scroll through the 24-hour log. Pressing **clear** returns to the Main Menu.

---

## Alarm Messages

The EP/2 displays alarm messages on the monitoring and parameters displays if a problem with one of the loads is detected. The messages are displayed in uppercase letters and flash on and off.

The following table lists the possible EP/2 alarm messages and provides a description of each. Some of the messages are general, but others are specific to certain load types. The LOAD TYPE column indicates whether the alarm message is load-specific or applies to all loads.

| ALARM         | DESCRIPTION  | LOAD TYPE |
|---------------|--|-----------|
| COMM LOSS     | The control module is not communicating with the EP/2.   | All       |
| DIRTY FILTER  | At the air filter, an insufficient air flow is being registered indicating a dirty filter. The filter switch has closed.   | ETM       |
| AIR FLOW      | The air flow input is active and the fan is enabled, but the switch does not detect air flow. All the outputs are forced off.  | ETM       |
| DRIFT ALARM   | The space temperature (heat or cool) is beyond and continuing to drift away from the setpoint.   | All       |
| PHASE LOSS    | One of the three phases of alternating electrical current being supplied to the facility has been lost. Closed contacts at the EP/2's Phase Loss input have shut off the designated loads. | All       |
| CONFIRM STAT  | A corresponding contact closure is not responding correctly to the on or off status of a load.   | All       |
| MAINT OVERRID | The "auto" setting of one of an IOM's On-Off -Auto switches has been manually overridden to on or off.   | IOM       |
| SENSOR FAULT  | An input sensor has shorted, failed, or the reading is outside the defined sensor range.   | All       |
| EMERG OVERRID | One of the conditions that has been defined in the software to activate an emergency and override a load's operation is occurring.   | All       |

This page intentionally left blank.