

INSTALLER'S GUIDE

**SENS-IN-1B
18-HD60D29-2**

Customer Property - Contains wiring, service, and operation information. Please retain.

Library	Service Literature
Product Section	Unitary
Product	Unitary Accessory
Model	T'stat, Panels, Timers, Relays
Literature Type	Installer's Guide
Sequence	1B
Date	March 1998
File No.	SV-UN-ACC-SENS-IN-1B 3/98
Supersedes	SENS-IN-1A

Model:	Used with:
BAYSENS019B	3-25 T. Packaged Heat/Cool YC/TC
ASYSTAT666B	3-20 T. Packaged Rooftop Heat Pumps
	27.5-50 T. Packaged Heat/Cool YC/TC/TE
	20-130 T. Packaged Rooftop Units
	20-80 T. Commercial Self-Contained Units

PROGRAMMABLE ZONE SENSOR FOR CONSTANT VOLUME (CV) UNITS AND HEAT PUMP (HP) UNITS

ABOUT THIS MANUAL

This manual is designed to help you make quick and correct use of your product. As with any product, we recommend that you take the time to read through the manual. We have, however, designed this manual so that you can easily and quickly find answers to your questions.

There are 4 sections:

Section	Page
1—Installation	2
2—Operation	5
3—Troubleshooting Guide and Icon Descriptions	11
4—Warranty and Return Information	13

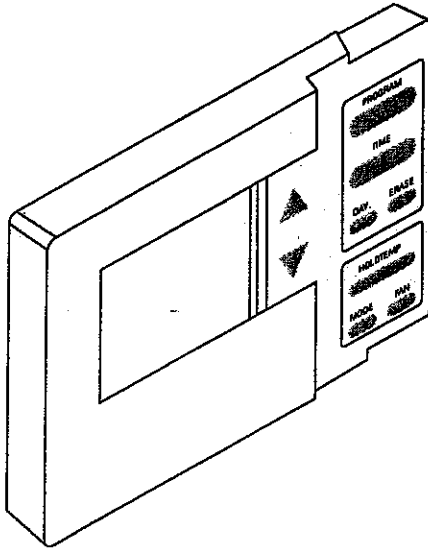

ZONE SENSOR ZSM

The Constant Volume (CV) Zone Sensor Module (ZSM) provides the programming and zone temperature sensing for the CV Unit Control Module (UCM), or the Unitary Control Processor (UCP).

ZSM is a programmable zone sensor designed to give you quick, flexible, and easy control over room temperature. With the ZSM you monitor and regulate temperature from a simple control pad connected to an easy-to-read (LCD) display.

The ZSM allows you to control temperature for a comfortable work environment and for money saving energy conservation, when work areas are not in use. Because your ZSM can partition each day of the week into 4 periods—giving you the ability to

alter room temperature through 28 distinct settings—you can regulate appropriate room temperature throughout the day and night. Furthermore, you can individualize each of the 4 periods into OCCUPIED or UNOCCUPIED status.

Any period has 2 adjustable temperature setpoints:

- Heat
- Cool

Once programmed, your ZSM retains both heat and cool settings in permanent memory for year round control. Even through extended power failures, your ZSM will preserve your program settings.

ZSM Installer's Guide
92K7301 Rev. B

INSTALLATION

- Inspection and Unpacking
- Installation Steps
 - Removing the ZSM from the Subbase
 - Mounting the Subbase
 - Wiring the Subbase
 - Mounting ZSM to the Subbase

INSPECTION & UNPACKING

Upon receipt of your *Zone Sensor Module*, immediately note visible damage to the exterior shipment packaging. Record any damage on the shipping documents.

Unpack the *ZSM* and carefully inspect it for obvious damage due to shipment.

If any damage has occurred, **YOU** must file a claim with the transporter. The transporter will not accept a claim from the shipper.

Within the package you will find 1 *Zone Sensor Module*, mounting hardware, and installation and operation instructions.

CAUTION

BEFORE YOU INSTALL THIS PRODUCT

1. Carefully read the installation instructions. Failure to follow the installation instructions could lead to equipment damage.
2. Do not exceed 30 VAC of applied voltage.
3. Before installing this product, disconnect the power supply to prevent electrical shock or equipment damage.
Use a voltmeter to verify that power is OFF.

INSTALLATION STEPS

Installing your *ZSM* requires 5 steps:

- Step 1—Selecting a Location
- Step 2—Removing the ZSM from the Subbase
- Step 3—Mounting the Subbase
- Step 4—Wiring the Subbase
- Step 5—Mounting the ZSM to the Subbase

STEP 1 - LOCATION

CAUTION

Do not install the *ZSM* in any location that may be affected by:

1. Drafts or dead spots behind doors or in corners.
2. Hot or cold air from ducts.
3. Radiant heat from sun or appliances.
4. Concealed pipes and chimneys.
5. Unheated or uncooled areas, such as an outside wall behind the *ZSM*.

Choose a location that is easily accessible, and on a wall where the subbase can be mounted about 5 feet (1.5 meters) above the floor.

The general area in which the *ZSM* is mounted should have good air circulation, and a constant, average temperature.

STEP 2 - REMOVING ZSM FROM THE SUBBASE

CAUTION

Electronic Sensitive Device

- Touching printed circuit board and electronic components may result in product damage.
- Avoid touching connector pins.
- Handle plastic housing only.

Note: Carefully hold the *ZSM* with one hand and firmly grasp the subbase with the other, as shown in Figure 1.1.

1. To remove the *ZSM* from the subbase, gently pull away and upward.

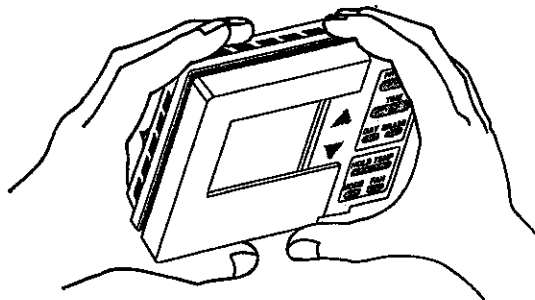

Figure 1.1
Removing the *ZSM* from the Subbase

INSTALLATION

STEP 2 - REMOVING ZSM FROM THE SUBBASE (Cont.)

2. After disassembly, protect the internal surfaces from contact with objects or substances that could cause damage.
3. Remove terminal block from subbase and set aside for wiring. Discard the tape.

STEP 3 - MOUNTING THE SUBBASE

NOTE: Use 18-22 AWG wire for connecting the ZSM.

To mount your *ZSM*, you will need the mounting hardware included in the shipping package. The mounting hardware is contained in a single plastic bag that includes:

- 3 plastic wall anchors
- 3 mounting screws

The *ZSM* subbase is designed to mount 1 of 2 ways:

- directly on a wall
- on an outlet box mounted to the wall (see instructions enclosed with mounting plate #BAYMTPL003B)

TO MOUNT THE SUBBASE DIRECTLY TO A WALL

Hold the subbase in position; mark three holes that will accept the plastic wall anchors. Drill three 3/16 inch (4.8 mm) holes. Gently tap the plastic wall anchors into the holes until the tops of the anchors are flush with the wall.

SECURING THE SUBBASE

When the plastic wall anchors are in place:

1. Pull *ZSM* wires through the subbase as shown in Figure 1.2 below.

Figure 1.2
Securing the Subbase

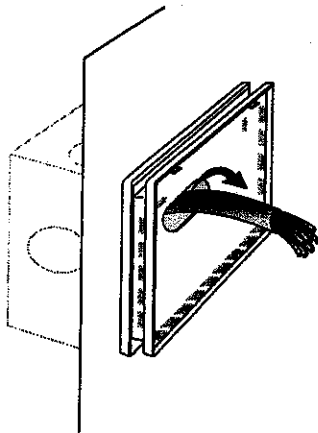

NOTE: A mounting plate and adapter kit (#BAYMTPL003B) is required to mount the *ZSM* subbase to an outlet box.

2. Loosely secure subbase to the wall with the mounting screws. **DO NOT TIGHTEN THE SUBBASE SCREWS YET.**
3. Level the subbase by sight, then firmly tighten the three subbase mountingscrews. **DO NOT OVER TIGHTEN SCREWS. OVERTIGHTENING THE SCREWS COULD CRACK THE SUBBASE.**

STEP 4 - WIRING THE SUBBASE

NOTE: Be sure to push excess wire back into the hole in the wall and plug the hole with nonflammable insulation to prevent drafts from affecting the temperature sensor.

All wiring must be Class II and comply with local electrical codes and ordinances. To wire your *ZSM* subbase, proceed with the following instructions:

1. To insure correct wiring when mounting a new *ZSM*, identify each wire before making any connections.
2. Identify the wires from the Unit Control Module (UCM) low voltage terminal strip. Each screw terminal is labeled.
3. Remove TB from subbase and discard the tape.
4. Strip the wires 1/4 inch and connect the wires from the *UCM's* low voltage terminal strip to the *ZSM* subbase. In general, Zone Sensor connections to the unit use the convention of connecting Zone Sensor terminals to like numbered terminals (6 to 6, 7 to 7, etc.). Connection detail is shown on the unit wiring diagrams which can be found in the unit service literature and on the unit.
5. Firmly tighten each screw terminal.
6. Fit the wires as close to the subbase as possible.

Figure 1.3
Terminal Block

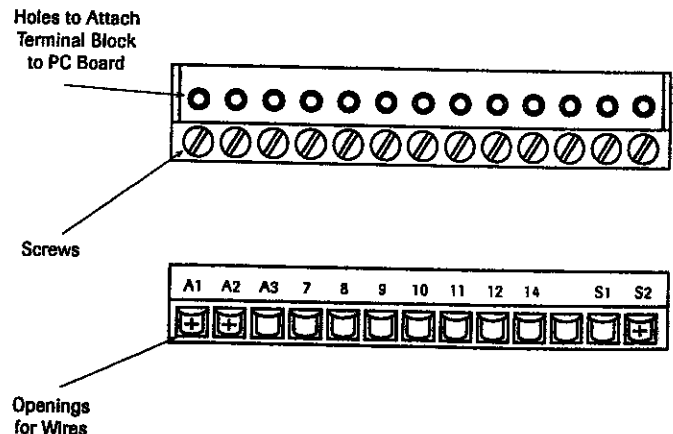

INSTALLATION

WIRING CONNECTIONS

Remote Panel Indicators—4 Wires

The *ZSM* has remote panel indications for four (4) signals from the *UCM*. Four (4) wires from the *UCM* should be connected to the terminal block on the *ZSM*.

Operating Power—2 Wires

A 24 VAC power line and a common from the *UCM* provides the operating power for the *ZSM*. These power lines should be connected to the terminal block on the *ZSM*.

Communication—1 Wire

Data communication between the *UCM* and the *ZSM* is accomplished over a serial link connected at terminal 12.

Remote Zone Temperature Sensor—2 Wires

The *ZSM* supports the use of a remote zone temperature sensor. The remote sensor should be a thermistor type sensor. When connecting the remote sensor, use terminals S1 and S2 on the subbase. Connect the drain wire from the shield to terminal 11.

Auxiliary Relay—3 Wires

The auxiliary relay is energized only during OCCUPIED periods. The auxiliary relay is form C, rated for 1.25 Amps at 30 VAC.

Your *ZSM* and subbase are purposefully designed to lock tightly so that the subbase can maintain the weight of the *ZSM* and not lose tension over the many life cycles of the product.

When mounting the *ZSM* to the subbase:

1. Attach terminal block to PC Board.

Figure 1.4

Attach Terminal Block to PC Board

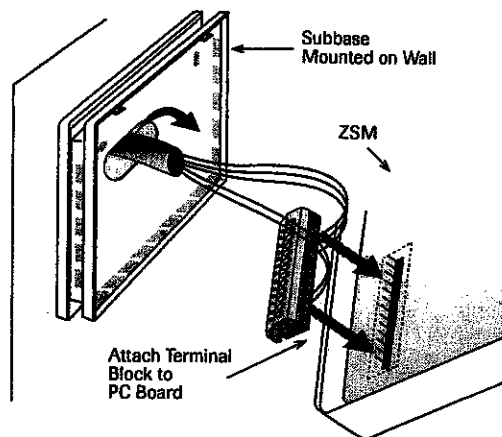

2. Hook the top two tabs on the *ZSM* to the slotted tabs on top of the subbase.
3. Swing the *ZSM* straight down onto the subbase until you hear the plastic locking mechanism snap into place.

Figure 1.5

Mounting the *ZSM* to the Subbase

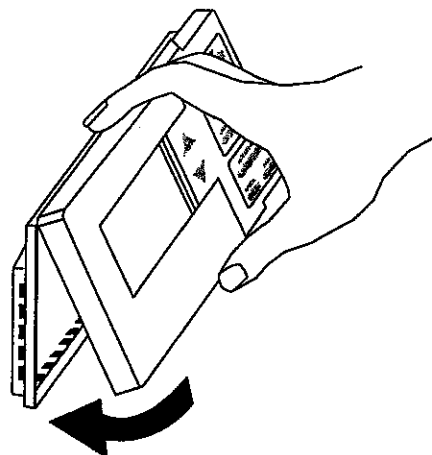

Note: Carefully align the *ZSM* locking mechanism with the mating locking mechanism on the subbase.

TERMINAL IDENTIFICATION TABLE

Terminal ID	Function
A1	Closed during Occupied Period
A2	Common for Auxiliary Relay
A3	Closed during Unoccupied Period
7	Status Input—Heat
8	Status Input—Cool
9	Status Input—ON
10	Status Input—Service
11	Transformer—Common
12	Data—Communications Link
14	Power 24 VAC—Hot Transformer
S1	Remote Sensor Input
S2	Remote Sensor Input

STEP 5 - MOUNTING THE ZSM TO THE SUBBASE

CAUTION

The plastic locking mechanism on the back of the *ZSM* must fit tightly to the subbase, but excessive force is not required to make this fit.

OPERATION

Figure 2.1
Keypad and Display Configuration

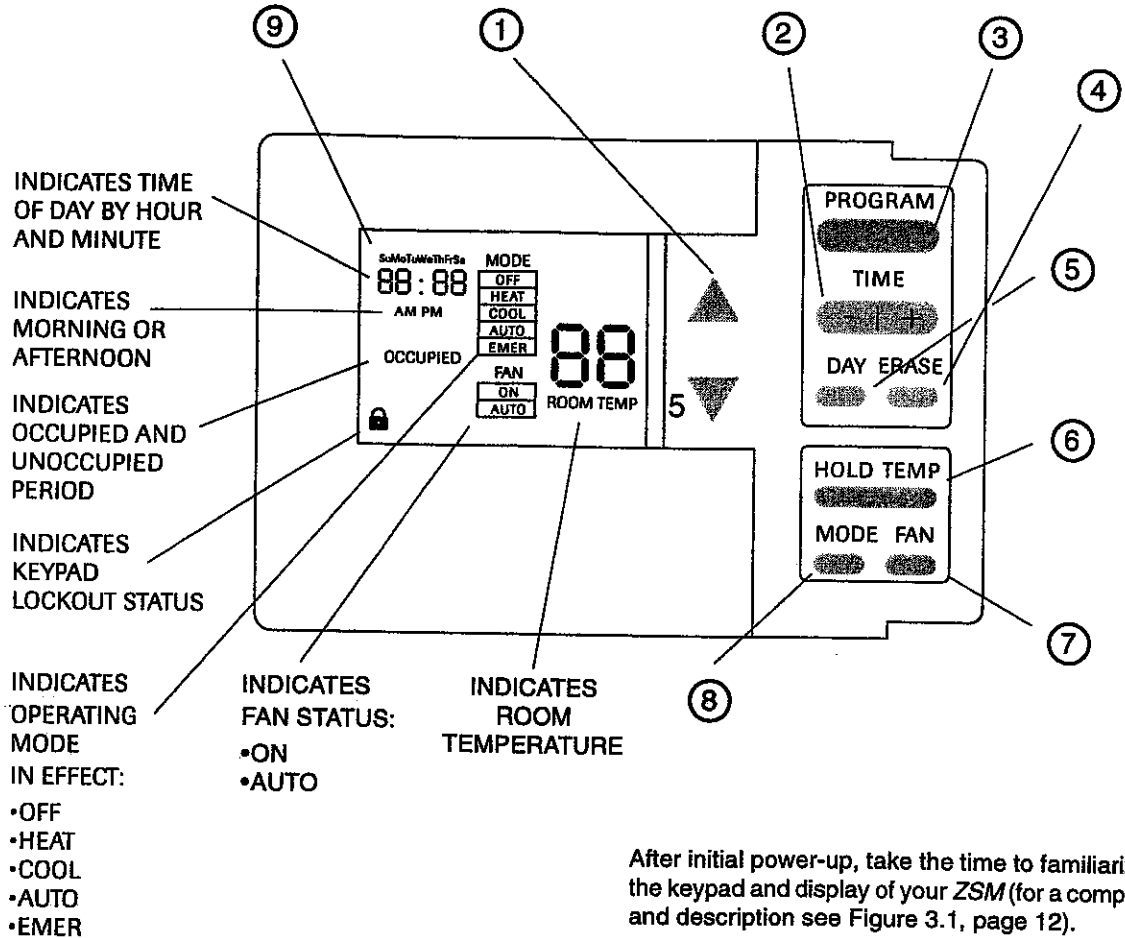

After initial power-up, take the time to familiarize yourself with the keypad and display of your ZSM (for a complete icon display and description see Figure 3.1, page 12).

① Up and Down Pushbuttons

- Increases or decreases programmed temperature settings in Program Menu.
- Shifts to Temporary Manual Override in Normal Run Mode.
- Increases or decreases temperature while in Temporary Override Menu.

② Time Adjust Pushbutton

Used to set the correct time of day. Used to set programmed time for temperature variations.

③ Program Pushbutton

Toggles between the Display control screen and the Display program screen.

④ Erase Pushbutton

- Erases time and temperature settings throughout each of the programmed periods.
- Exits Temporary Manual Override.

⑤ Day Pushbutton

Toggles through the seven days of the week.

⑥ Hold Temp Pushbutton

Shifts controller to temporary manual override, and begins Temperature Override.

⑦ Fan Pushbutton

Toggles the fan controller between ON and AUTO mode.

⑧ Mode Pushbutton

Toggles the controller through its 4 modes: OFF, HEAT, COOL, and AUTO; if HP version, also EMER (Emergency).

⑨

- Indicates day of the week
- Indicates begin time in Program Menu
- Indicates time setting in Temporary Override Mode

OPERATION

- Initial Power-Up
- Time and Day Settings
- Features
- Keypad Operation
- Keypad Operation for Temporary Manual Override Menu
- Temporary Manual Override Run Mode
- Option Menu and Keypad Operation
- Intelligent Copy
- Remote Panel Indicator Signals from UCM to ZSM

INITIAL POWER-UP

Before applying power to your ZSM, and before performing setup and operation procedures, verify that all wiring is correct.

TIME AND DAY SETTINGS

On power-up, your ZSM will be in Normal Run Mode and will begin operating using factory setpoints. The display will show the wrong day and time and will need to be set.

To set the time, there is a single rubber pushbutton on the keypad — | + marked TIME.

Depressing the positive side will advance the time.
Depressing the negative side will decrease the time.

Each time you depress the positive or negative side — | + , the time will either advance or decrease respectively by one minute. If you press and hold either side of the time pushbutton, the time change will accelerate rapidly.

When you reach the correct time, release the time button and the time will be set into permanent memory.

Note: To insure that you really want to make time changes, the ZSM will initiate a 30 second user stabilization time before making changes to the ZSM mode of operation.

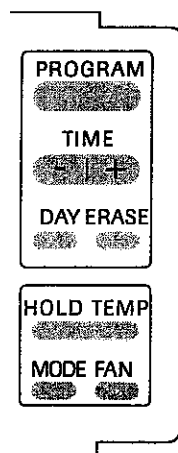

KEYPAD OPERATION

Remember: Once you have toggled to the program screen the week is divided into 7 days and each day is divided into 4 periods. You will have 28 possible program settings.

PROGRAM PUSHBUTTON

Depressing the program pushbutton PROGRAM will toggle the Display from Normal Run Mode (see Figure 2.1) to the Program Menu (see Figure 2.2). Before toggling to the Program Menu, use the mode pushbutton to select the type of setpoints you want to review or program (Heat, Cool or Auto). For example, if you select COOL mode before toggling to the program menu, then only the COOL setpoints will be reviewed or programmed. If you select HEAT mode, then only the HEAT setpoints will be reviewed or programmed. In AUTO mode, both HEAT and COOL setpoints will reviewed or programmed.

Figure 2.2
Display Program Menu Screen

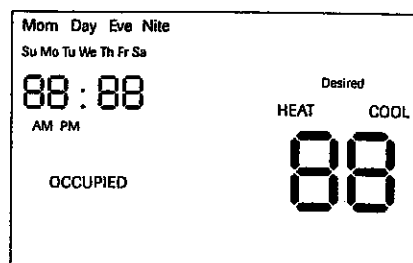

- While in Program Menu, each time you press and release the Program Pushbutton PROGRAM , the ZSM toggles through the 4 periods that divide each day. Those 4 periods are: Morn (ing), Day, Eve (ning), and Nite.
- To exit Program Menu, hold PROGRAM pushbutton for 2 seconds.

TIME PUSHBUTTON

- While in Program Menu, each time you press and release the positive or negative side of the Time Pushbutton — | + , the time will advance or decrease by 10 minute increments. If you press and hold the positive or negative side — | + , the ZSM will increment rapidly.
- When the display is in the Normal Run Mode, each time you press and release the positive or negative side of the Time Pushbutton — | + , the time will advance or decrease by 1 minute. If you press and hold the positive or negative side — | + , the ZSM will increment rapidly.

OPERATION

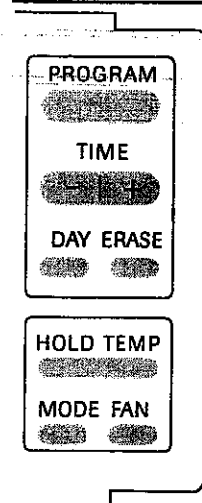

Note: Blank temperature settings may be entered at any of the 4 daily periods. When a setpoint is left blank and in an occupied condition, the ZSM will default to the last occupied setpoint. When a setpoint is left blank and in an unoccupied condition, the ZSM will default to the last unoccupied setpoint.

KEYPAD LOCKOUT

If you simultaneously depress and hold both the positive and negative sides of the $-|+$ for 4 seconds, the lock icon will appear and all keypad functions will be locked out. If you repeat this operation, the lock icon will disappear and all keypad functions will be available again.

- Keypad Lockout applies only to Normal Run Mode and Temporary Manual Override Mode.

DAY PUSHBUTTON

- In Normal Run Mode, depressing the DAY pushbutton will move the current day ahead.
- While in the Program Menu, depressing the DAY pushbutton will move you through the 7 days of the week and allow you to program temperature settings for each of the 4 daily periods.

ERASE PUSHBUTTON

- Pressing the ERASE pushbutton while in Normal Run Mode will turn off the check filter icon.
- Pressing the ERASE pushbutton while in Program Menu, will erase all time and temperature setpoints of a given period.
- Pressing the ERASE pushbutton for 5 seconds while in Program Menu will erase all time and temperature settings.
- ERASE will acknowledge failure buzzer (Option 16) until 12:00 am.

MODE PUSHBUTTON

- Pressing the MODE pushbutton toggles through all modes: OFF, HEAT, COOL, AUTO, and EMER (HP unit).

FAN PUSHBUTTON

- The FAN pushbutton allows you to toggle between ON and AUTO.

UP AND DOWN PUSHBUTTON ARROWS

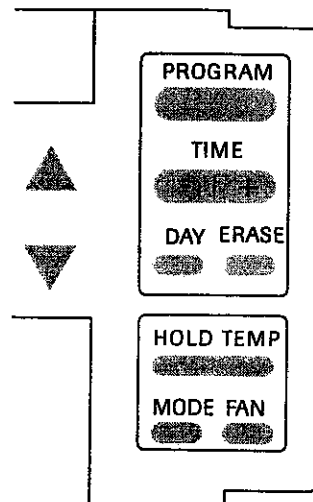

- Depressing either \blacktriangle or \blacktriangledown arrow while in Normal Run Mode will cause your ZSM to shift to Temporary Manual Override Menu.
- Depressing either \blacktriangle or \blacktriangledown arrow while in Program Menu or Temporary Override Menu will cause the temperature setpoint to advance or decrease in 1 degree increments.
- Depressing and holding either the \blacktriangle or \blacktriangledown arrow will cause the temperature setting to increment rapidly.

Simultaneously depressing the \blacktriangle or \blacktriangledown arrow for 2 seconds while in Program Menu or Temporary Override Menu will toggle the ZSM between an occupied and unoccupied condition.

HOLDTEMP PUSHBUTTON

While in Normal Run Mode, depressing the HOLD TEMP pushbutton shifts the ZSM to a Temporary Manual Override Menu (see Figure 2.3).

This mode is used to override any number of programmed setpoints through any of the 28 programmed periods. After the desired setpoints and length of override time is entered, these new settings will be used in place of the setpoints programmed for Normal Run Mode.

Figure 2.3

Temporary Manual Override Menu Display

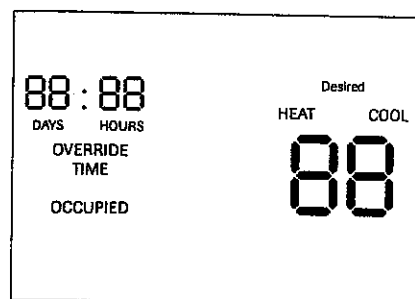

KEYPAD OPERATION FOR TEMPORARY MANUAL OVERRIDE MENU

The keypad has the same function in Temporary Manual Override Menu as in all other menus, with a few notable exceptions:

- Depressing the DAY pushbutton will toggle your ZSM between the DAY and HOUR icon (see Figure 2.3).
- Depressing the MODE pushbutton will toggle your ZSM between the HEAT and COOL icons and setpoints.
- Depressing the ERASE pushbutton will cancel the override and return the ZSM to Normal Run Mode.
- Depressing the HOLD TEMP or PROGRAM pushbuttons while in Temporary Manual Override Menu will toggle your ZSM to Temporary Override Mode (see Figure 2.4).

Figure 2.4

Override Run Mode

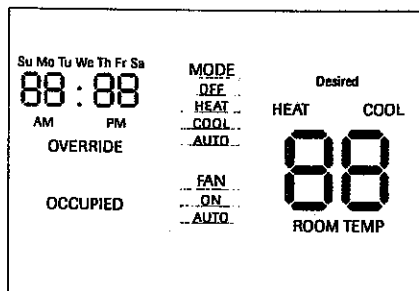

TEMPORARY OVERRIDE RUN MODE

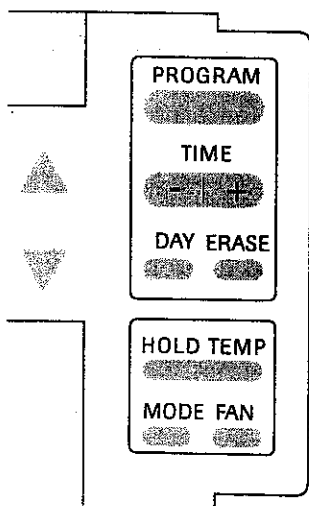

The Temporary Override Run Mode sends setpoint data to the Unit Control Module (UCM) from the setpoint data entered in the Temporary Manual Override Menu.

In Temporary Override Run Mode, most of the keypad functions are locked out with a few notable exceptions:

- The MODE pushbutton still functions as in Normal Run Mode.
- The FAN pushbutton still functions as in Normal Run Mode.

- Depressing the HOLDTEMP pushbutton toggles the ZSM between Temporary Manual Override Menu and Override Run Mode. (If no pushbutton is pressed for 20 seconds while in Temporary Manual Override Menu, the ZSM exits to Normal Run Mode, ignoring the Temporary Override settings.)

- Depressing either the ▲ or ▼ arrow while in Override Run Mode will cause the ZSM to toggle to Temporary Manual Override Menu.
- The ERASE pushbutton will turn off the Check Filter icon if displayed.
- Simultaneously depressing and holding the positive and negative sides of the - | + for 4 seconds will lock out the keypad.
- Time is not adjustable in this mode.
- PROGRAM pushbutton is disabled.

OPTION MENU AND KEYPAD OPERATION

The Option Menu is used to set all programmable options built into your ZSM. All options are retained in permanent EEPROM memory.

To access the Option Menu Display (see Figure 2.5), simultaneously depress and hold the MODE pushbutton and the PROGRAM pushbutton for 4 seconds.

When the Option Menu is displayed, the only active pushbuttons are the ▲ and ▼ arrows and the - | + pushbutton. The ▲ and ▼ arrows increment through the available options by number (1-24), and the - | + pushbutton toggles through the various option values associated with each option number (see Figure 3.6).

Figure 2.5

Typical Option Menu Display

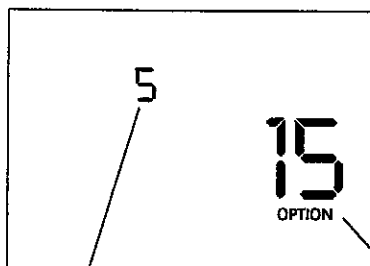

For Example:

In Figure 2.5, option 15 is displayed and indicates the Initial Timer Setting in the Temporary Override Run Mode. The value of the option in this case is in hours, and the value selected is 5 hours.

OPERATION

Figure 2.6

ZSM Option Menu Settings

Note: Changing either option 9 or 10 will erase the current program. To avoid reprogramming, set options 9 and 10 before programming.

Option #	Description	Value	Factory Setting
1	Morning warm-up	0 = Disabled 1 = Enabled	0
2	Economizer minimum position override	0 = Disabled 1 = Enabled	1
3	Temperature Scale	0 = Fahrenheit 1 = Centigrade	0
4	Supply Air Tempering	0 = Disabled 1 = Enabled	0
5	Time Clock	0 = 12 hour 1 = 24 hour	0
6	Smart Fan	0 = Disabled 1 = Enabled	1
7	Intelligent Temperature Recovery	0 = Disabled 1 = Enabled	0
8	Programmable Days/Week	0 = 7 days (M, T, W, T, F, S, S) 1 = 3 days (M-F, S, S) 2 = 2 days (M-F, S-S) 3 = 1 day (Sun-Sat)	0
9	Programmable Periods/Day	2, 3, 4	4
10	Programmable Fan Operation	0 = Disallowed 1 = Allowed	0
11	Remote Sensor Installed	0 = No 1 = Yes	0
12	Check Filter Interval	0 = Disabled 3000 to 50 in 50 hour increments	350
13	Display Zone Temperature	0 = No 1 = Yes	1
14	Keypad Lockout Enabled	0 = Disabled 1 = Enabled	1
15	Initial Time Setting in Temporary Override Mode (in hours)	1, 2, 3, 4, 5	3
16	Buzzer Options	0 = Key Press Only 1 = Key Press and Check Filter 2 = Key Press, Check Filter, and System Failures	1
17	Zone Temperature Calibration	Displays current temperature reading with any offsets	0 offset
18	Baud Rate	0 = 1024 baud 1 = 1200 baud	1
19	CV or HP Operation	0 = CV 1 = HP	0
20	Default Cooling Setpoint	45 to 98	74
21	Default Heating Setpoint	43 to 96	68
22	Minimum Cooling Setpoint	45 to 98	45
23	Maximum Heating Setpoint	43 to 96	96

OPERATION

INTELLIGENT COPY

Note: Once you have used Intelligent Copy, you cannot use it again until you ERASE all weekday and weekend time periods by pressing ERASE for 5 seconds.

If your heating and cooling requirements are the same for each day of the week, and for each day of the weekend, your ZSM is designed to employ Intelligent Copy.

To program the five weekdays—Monday through Friday—you need to program only one weekday; likewise, to program the weekend—Saturday and Sunday—you need to program only one day. After programming one weekday and/or one weekend day, Intelligent Copy automatically copies your program to the other days.

To use Intelligent Copy:

1. Be sure you have selected the seven day programming format in the Options Menu (see Figure 2.6).
2. Be sure that the entire program is blank.
3. Go to Program Menu.
4. Enter your setpoint parameters. Intelligent Copy will automatically copy these parameters to the other weekdays.
5. Depress the DAY pushbutton until a weekend day icon appears.
6. Enter your setpoint parameters. Intelligent Copy will automatically copy these parameters to the other weekend day.

REMOTE PANEL INDICATOR SIGNALS FROM UCM TO ZSM

The Unit Control Module (UCM) can send four signals to your ZSM (see Figure 2.7):

- Heat
- Cool
- ON
- Service

Figure 2.7

UCM Signals to ZSM

Note: Each of these 4 signals will have one of 3 conditions (see Figure 2.8):

- OFF
- ON
- FLASHING

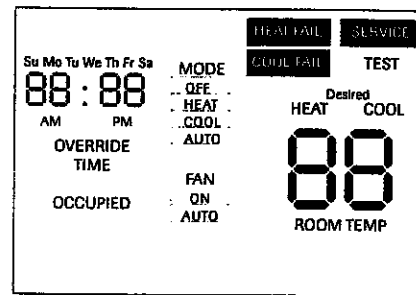

Figure 2.8

UCM Signals Conditions

Terminal #	Signal	Condition
7 (HEAT)	ON	HEAT is ON and indicated by a solid HEAT icon in the Display.
	Flashing	Failure in the heating system indicated by a flashing HEAT FAIL icon.
8 (COOL)	ON	COOLING is ON and indicated by a solid COOL icon in the Display.
	Flashing	Failure in the cooling system indicated by a flashing COOL FAIL icon.
9 (ON)	OFF	System is OFF and indicated by a solid colon on the time of day display.
	ON	System is ON and indicated by a flashing colon on the time of day display.
	Flashing	System is in TEST mode and indicated by a flashing TEST icon.
10 (SERVICE)	ON	System requires service and is indicated by a solid SERVICE icon.
	Flashing	There is a FAN failure indicated by a flashing SERVICE icon.

Notes:

1. There is no indication for a signal in the OFF condition.
2. If Option 16 is set to "2," any flashing signals will also give audible buzzer indication.

TROUBLESHOOTING GUIDE

Problem	Solution
Display does not come on.	Check for power at terminals 11 and 14 (nominal 24 VAC). Be sure that the terminal block is properly mounted on its pins.
No communications to UCM.	Check for voltage between terminals 11 and 12 (range is 22-42 Vdc). Check wiring to UCM if voltage is not present.
Displayed zone temperature reads Sh and a COOL FAIL is displayed solid.	<ol style="list-style-type: none"> 1. Check option 11 to see if remote sensor is installed. If remote sensor is installed, check the wiring from terminals S1 and S2 to the remote sensor for a shorted circuit condition. 2. If option 11 has a 0 value, then a local sensor is selected and the on-board thermistor is shorted and the sensor should be replaced.
Displayed zone temperature oP and a COOL FAIL is displayed solid.	<ol style="list-style-type: none"> 1. Check option 11 to see if remote sensor is installed. If remote sensor is installed, check the wiring from terminals S1 and S2 to the remote sensor for an open circuit condition. 2. If option 11 has a 0 value, then a local sensor is selected and the on-board thermistor is open and the sensor should be replaced.
Zone temperature is not displayed.	Display Zone temperature option has been accessed and locked out. Check option 13. The option value should be 1.
ZSM is not responding to pushbuttons.	The ZSM is in keypad lockout mode. Go to Keypad Operation-Keypad Lockout in Section 2 of this manual and follow instructions to return keypad functions.
The clock requires reprogramming after a short power interruption.	Replace the battery.
Fan switch is in ON position but fan is not running.	Check option 6 in the Option Menu. Smart fan overrides the last part of an unoccupied period.
System is operating before programmed start time.	Check option 7 in the Option Menu. Computed recovery overrides the last part of an unoccupied period to obtain the occupied settings in time.
Buzzer indicates System failure or service required.	Press ERASE to acknowledge buzzer until noon the next day.

ICON DISPLAY AND DESCRIPTIONS

Figure 3.1
Complete Icon Display

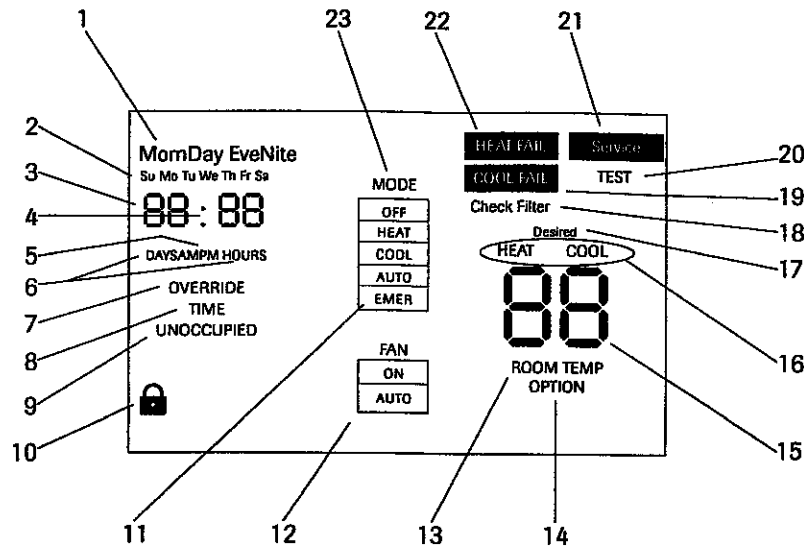

Icon Descriptions

1. The four periods of the day used only during programming mode.
2. The seven days of the week used during programming and in normal mode to display the day (not current in Program Menu).
3. Four digits used to display the time of day in normal run mode. Also used in Programming Menu and Temporary Manual Override Menu, and options menu.
4. Time of day colon used on the time of day clock. The colon blinks to indicate the UCM system is functional.
5. AM and PM are used to indicate the time of day when using a 12 hour clock. AM and PM are not used when a 24 hour clock is selected.
6. DAYS and HOURS are used to set the override timer period.
7. Displayed in temporary manual OVERRIDE mode, and when setting the override timer.
8. Only used when setting the override timer.
9. Displays the desired state of either OCCUPIED or UNOCCUPIED.
10. The padlock symbol indicates that the keyboard lockout is in effect.
11. This extends the mode selection box in order to accommodate the emergency heat mode on the ZSM heat pump version.
12. FAN mode selection box.
13. Displayed in normal run mode when displaying the actual room temperature.
14. Displayed in option setting mode only.
15. Digits used to display temperature.
16. HEAT and COOL have two functions: They indicate UCM status in normal run mode and indicate which type of setpoint is DESIRED during programming and override setting.
17. Only used during programming and override setting to indicate the DESIRED setpoint temperature.
18. Flashes when check filter timer is elapsed.
19. Flashing cooling fail status indicator.
20. Only used during UCP self-test mode.
21. Flashing service status indicator and fan failure.
22. Flashing heating fail status indicator.
23. Operating MODE selection box.

WARRANTY

WARRANTY NOTICE

This warranty complies with the Federal Law applicable to products manufactured after December 31, 1976.

This warranty gives you specific legal rights. You may also have other rights which vary from state to state.

WARRANTY

The supplier warrants their products against defects in workmanship and material. No other express warranty, written or oral, applies with the exception of a written statement from an officer of the supplier.

WARRANTY PERIOD

This warranty extends for twelve months from the date of shipment from the factory or an authorized distributor.

LIMITATIONS

Products must be installed and maintained in accordance with enclosed user installation instructions. Users are responsible for suitability of the products to their application. There is no warranty against damage resulting from corrosion, misapplication, improper specification or other operating conditions beyond our control. Claims against carriers for damage in transit must be filed by the buyer.

WEEKLY PROGRAM SHEET

Monday	Begin Time	Heat Setpoint	Cool Setpoint	Occupied/Unoccupied
Morn				Occ / Un
Day				Occ / Un
Eve				Occ / Un
Nite				Occ / Un

Tuesday	Begin Time	Heat Setpoint	Cool Setpoint	Occupied/Unoccupied
Morn				Occ / Un
Day				Occ / Un
Eve				Occ / Un
Nite				Occ / Un

Wednesday	Begin Time	Heat Setpoint	Cool Setpoint	Occupied/Unoccupied
Morn				Occ / Un
Day				Occ / Un
Eve				Occ / Un
Nite				Occ / Un

Thursday	Begin Time	Heat Setpoint	Cool Setpoint	Occupied/Unoccupied
Morn				Occ / Un
Day				Occ / Un
Eve				Occ / Un
Nite				Occ / Un

Friday	Begin Time	Heat Setpoint	Cool Setpoint	Occupied/Unoccupied
Morn				Occ / Un
Day				Occ / Un
Eve				Occ / Un
Nite				Occ / Un

Saturday	Begin Time	Heat Setpoint	Cool Setpoint	Occupied/Unoccupied
Morn				Occ / Un
Day				Occ / Un
Eve				Occ / Un
Nite				Occ / Un

Sunday	Begin Time	Heat Setpoint	Cool Setpoint	Occupied/Unoccupied
Morn				Occ / Un
Day				Occ / Un
Eve				Occ / Un
Nite				Occ / Un

- Notes:**
1. DEFAULT TEMPERATURES - The ZSM controls to 68°F (Heat), and 74°F (Cool) until the user enters their personal program.
 2. DEFAULT PERIODS - Prior to user programming, the MORN and DAY periods default to an OCCUPIED status, and the EVE and NITE periods default to an UNOCCUPIED status. Simultaneously holding the ▲ and ▼ arrows for two seconds will change the occupied/unoccupied status during program entry.